

DUKANE

Projector

6540HL / 6542WL

User's Manual

TABLE OF CONTENTS

Supplier's Declaration of Conformity	III
Important Information	IV

INTRODUCTION 1

Package Overview.....	1
Product Overview	2
Connections.....	3
Keypad	4
Remote control	5
Power cord	7
AC adapter	7

SETUP AND INSTALLATION 8

Installing the projector	8
Connecting to a computer	9
Connecting to a Media player.....	10
Adjusting the projector image.....	11
Remote setup	13

USING THE PROJECTOR..... 15

Powering on / off the projector.....	15
Selecting an input source	16
Menu navigation and features	17
OSD Menu tree.....	18
Display image settings menu.....	21
Display 3D menu	22
Display aspect ratio menu	23
Display zoom menu.....	26
Display keystone menu	26
Audio mute menu	27
Audio volume menu.....	27
Setup projection menu.....	28
Setup projection location menu	28
Setup power settings menu	28
Setup security menu.....	28
Setup HDMI CEC menu	31
Setup test pattern menu	31
Setup options menu.....	31
Info menu.....	32

ADDITIONAL INFORMATION	33
Compatible resolutions	33
Image size and projection distance	39
Projector dimensions and ceiling mount installation.....	41
RS232 Commands and Protocol Function List.....	42
Troubleshooting	43
Warning indicators	45
Specifications	46
Maintenance	48
Cabinet dimensions	49

Supplier's Declaration of Conformity

This device complies with Part 15 of the FCC Rules. Operation is subject to the following two conditions: (1) This device may not cause harmful interference, and (2) this device must accept any interference received, including interference that may cause undesired operation.

Responsible Party:

WARNING:

FCC Regulations state that any unauthorized changes or modifications to this equipment not expressly approved by the manufacturer could void the user's authority to operate this equipment.

NOTE:

This equipment has been tested and found to comply with the limits for a Class B digital device, pursuant to Part 15 of the FCC Rules. These limits are designed to provide reasonable protection against harmful interference in a residential installation.

This equipment generates, uses and can radiate radio frequency energy and, if not installed and used in accordance with the instructions, may cause harmful interference to radio communications. However, there is no guarantee that interference will not occur in a particular installation.

If this equipment does cause harmful interference to radio or television reception, which can be determined by turning the equipment off and on, the user is encouraged to try to correct the interference by one or more of the following measures:

- Reorient or relocate the receiving antenna.
- Increase the separation between the equipment and receiver.
- Connect the equipment into an outlet on a circuit different from that to which the receiver is connected.
- Consult the dealer or an experienced radio/TV technician for help.

Important Information

Laser Safety Caution

Obey the laws and regulations of your country in relation to the installation and management of the device.
This product is classified as Class 1 of IEC 60825-1:2014 and RG2 of IEC 62471-5:2015.

WARNING

CLASS 1 LASER PRODUCT OF IEC 60825-1:2014

- Use of controls or adjustments or performance of procedures other than those specified herein may result in hazardous radiation exposure.
Laser energy exposure near aperture may cause burns.

Risk group 2 (RG2)

WARNING

- As with any bright light source, do not stare into the beam, RG2 IEC/EN 62471-5:2015.

USA only

- Complies with 21 CFR 1040.10 and 1040.11 except for conformance as a Risk Group 2 LIP as defined in IEC 62471-5:Ed. 1.0. For more information see Laser Notice No. 57, dated May 8, 2019.

WARNING

- Do not allow to look into the projector beam at any distance from the projector. An adult should supervise the children to prevent exposure risks.
- Check that there is no one looking at the lens, when using the remote control for starting the projector.
- Do not look at the projected light using optical devices (binoculars, telescopes, magnifying glasses, reflectors, etc).
- [WARNING: MOUNT ABOVE THE HEADS OF CHILDREN.]
The use of a ceiling mount is recommended with this product to place it above the eyes of children.



Laser Information

- Wave length: 449-461nm
- Maximum power: 54W









About the symbols

To ensure safe and proper use of the product, this manual uses a number of symbols to prevent injury to you and others as well as damage to property.

The symbols and their meanings are described below. Be sure to understand them thoroughly before reading this manual.

 WARNING	Failing to heed this symbol and handling the product erroneously could result in accidents leading to death or major injury.
 CAUTION	Failing to heed this symbol and handling the product erroneously could result in personal injury or damage to surrounding property.

Examples of symbols

	This symbol indicates you should be careful of electric shocks.
	This symbol indicates you should be careful of high temperatures.
	This symbol indicates something that must be prohibited.
	This symbol indicates something that must not be got wet.
	This symbol indicates you should not touch with wet hands.
	This symbol indicates something that must not be disassembled.
	This symbol indicates things you must do.
	This symbol indicates that the power cord should be unplugged from the power outlet.

! WARNING

Projected light

Projected light and the pictogram/label indicated on the cabinet

- This product is classified as Class 1 of IEC 60825-1:2014.
- Do not look into the projector's lens.
Strong light that could damage your vision is projected when the projector is operating. Laser energy exposure near aperture may cause burns. Be especially careful when children are around.
- Do not look at the projected light using optical devices (magnifying glasses, reflectors, etc.). Doing so could result in vision impairment.
- Check that there is no one looking at the lens within the projection range before turning on the projector.
- Do not allow children to operate the projector alone. When a child is operating the projector an adult should always be present and watch the child carefully.
- The below pictogram, that is indicated near the lens on the cabinet, describes this projector is categorized in the risk group 2 of IEC 62471-5:2015. As with any bright light source, do not stare into the beam, RG2 IEC 62471-5:2015.

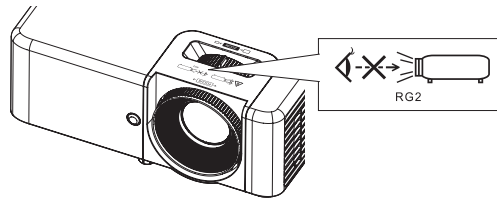

- The caution and the explanatory labels of the LASER PRODUCT in Class 1 conforming to IEC 60825-1:2014 are stuck on the below indicated positions.

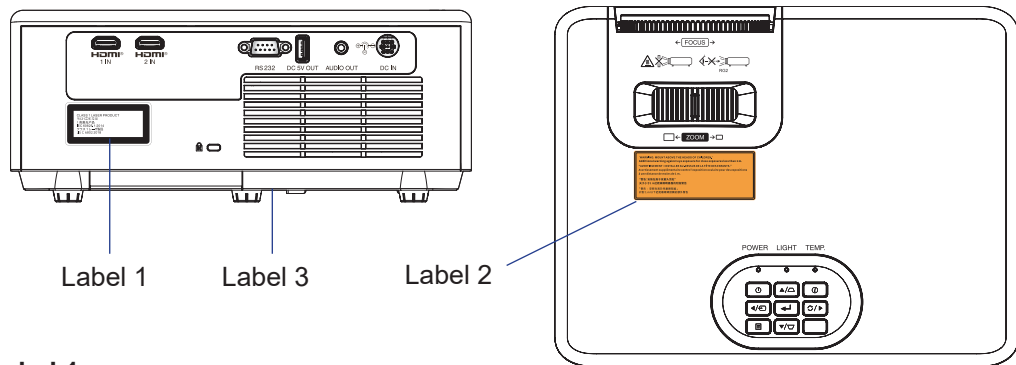

Label 1 Class 1 laser product label



Label 2 FDA additional warning label (For USA only)

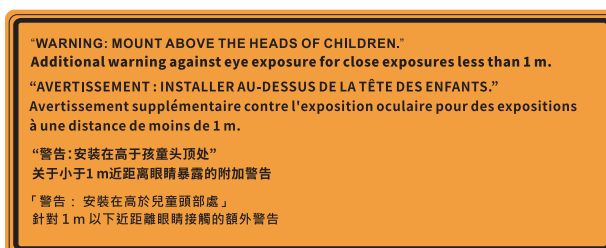





⚠ WARNING

 PROHIBITED	<p>Label 3 Product label (Rating label/ID label) on the bottom of the product</p> <div style="display: flex; justify-content: space-around;"> <div style="border: 1px solid black; padding: 5px; width: 45%;"> <p>SHARP PROJECTOR MODEL XP-M401H-W</p> <p>VOLTS : 19.5V ~~~ AMPERES : 11.79A SERIAL NO. _____</p> <p style="font-size: 8px;">Complies with 21 CFR 1040.10 and 1040.11 except for conformance as a Risk Group 2 LP as defined in IEC 62471-5:Ed. 1.0. For more information see Laser Notice No. 57, dated May 8, 2019.</p> <div style="border: 1px solid black; padding: 2px; font-size: 8px;"> CAN ICES-003(B) / NMB-003(B) THIS DEVICE COMPLIES WITH PART 15 OF THE FCC RULES. OPERATION IS SUBJECT TO THE FOLLOWING TWO CONDITIONS: (1) THIS DEVICE MAY NOT CAUSE HARMFUL INTERFERENCE, AND (2) THIS DEVICE MUST ACCEPT ANY INTERFERENCE RECEIVED, INCLUDING INTERFERENCE THAT MAY CAUSE UNDESIRABLE OPERATION. </div> <p style="font-size: 8px;">THIS CABINET IS CONSTRUCTED OF PLASTIC(P). CAUTION : TO PREVENT ELECTRIC SHOCK, DO NOT OPEN TOP COVER. NO USER-SERVICEABLE PARTS INSIDE. ATTENTION : AFIN DE PREVENIR UN CHOC ELECTRIQUE, NE PAS ENLEVER LE COUVERCLE. <small>ADRESSER A UN REPARATEUR COMPETENT.</small> Sharp NEC Display Solutions, Ltd. 4-28, Mita 1-chome, Minato-ku, Tokyo, Japan MADE IN CHINA >PET<</p> </div> <div style="border: 1px solid black; padding: 5px; width: 45%;"> <p>SHARP PROJECTOR MODEL XP-M421W-W</p> <p>VOLTS : 19.5V ~~~ AMPERES : 11.79A SERIAL NO. _____</p> <p style="font-size: 8px;">Complies with 21 CFR 1040.10 and 1040.11 except for conformance as a Risk Group 2 LP as defined in IEC 62471-5:Ed. 1.0. For more information see Laser Notice No. 57, dated May 8, 2019.</p> <div style="border: 1px solid black; padding: 2px; font-size: 8px;"> CAN ICES-003(B) / NMB-003(B) THIS DEVICE COMPLIES WITH PART 15 OF THE FCC RULES. OPERATION IS SUBJECT TO THE FOLLOWING TWO CONDITIONS: (1) THIS DEVICE MAY NOT CAUSE HARMFUL INTERFERENCE, AND (2) THIS DEVICE MUST ACCEPT ANY INTERFERENCE RECEIVED, INCLUDING INTERFERENCE THAT MAY CAUSE UNDESIRABLE OPERATION. </div> <p style="font-size: 8px;">THIS CABINET IS CONSTRUCTED OF PLASTIC(P). CAUTION : TO PREVENT ELECTRIC SHOCK, DO NOT OPEN TOP COVER. NO USER-SERVICEABLE PARTS INSIDE. ATTENTION : AFIN DE PREVENIR UN CHOC ELECTRIQUE, NE PAS ENLEVER LE COUVERCLE. <small>ADRESSER A UN REPARATEUR COMPETENT.</small> Sharp NEC Display Solutions, Ltd. 4-28, Mita 1-chome, Minato-ku, Tokyo, Japan MADE IN CHINA >PET<</p> </div> </div>
--	---

Power supply

 REQUIRED	<p>Use a suitable voltage power supply.</p> <ul style="list-style-type: none"> This projector is designed to be used with a 100–240 VAC, 50/60 Hz power supply. Before using the projector, check that the power supply to which the projector is to be connected meets these requirements. Use a power outlet as the projector’s power supply. Do not connect the projector directly to electrical light wiring. Doing so is dangerous.
--	---

 MUST BE EARTHED	<p>Connecting the power cord to earth</p> <ul style="list-style-type: none"> This equipment is designed to be used in the condition of the power cord connected to earth. If the power cord is not connected to the earth, it may cause electric shock. Please make sure the power cord is connected to the wall outlet directly and earthed properly. Do not use a 2-pin plug converter adapter. Be sure to connect the projector and the computer (signal source) to the same earth point. If the projector and the computer (signal source) will be connected to different earth points, fluctuations in the earth potential may cause fire or smoke.
--	---

 REQUIRED	 PROHIBITED	 HAZARDOUS VOLTAGE	 DO NOT TOUCH WITH WET HANDS	<p>Handling the AC adapter and the power cord</p> <ul style="list-style-type: none"> Please use the AC adapter and the power cord supplied with this projector. If the supplied power cord does not satisfy the requirements of your country’s safety standard, and voltage and current for your region, make sure to use the power cord that conforms to and satisfies them. The power cord you use must be approved by and comply with the safety standards of your country. Please refer to the “Specifications” in the User’s Manual about the power cord specification. For selecting an appropriate power cord, please check rated voltage for your region by yourself. The AC adapter and the power cord included with this projector is exclusively for use with this projector. For safety, do not use it with other devices. Handle the AC adapter and the power cord with care. Damaging the cord could lead to fire or electric shock. <ul style="list-style-type: none"> Do not place heavy objects on the cord. Do not place the cord under the projector. Do not cover the cord with a rug, etc. Do not scratch or modify the cord. Do not bend, twist or pull the cord with excessive force. Do not apply heat to the cord. <p>Should the AC adapter and the power cord be damaged (exposed core wires, broken wires, etc.), ask your dealer to replace it.</p> <ul style="list-style-type: none"> Do not touch the power plug should you hear thunder. Doing so could result in electric shock. Do not connect or disconnect the AC adapter and the power cord with wet hands. Doing so could result in electric shock.
--	--	---	---	--

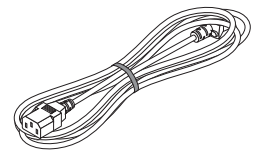

WARNING

Installation



PROHIBITED



DO NOT WET



**UNPLUG THE
POWER CORD**

Do not use in places such as those described below.

- Do not use in places such as those described below. Doing so could lead to fire or electric shock.
 - Shaky tables, inclined surfaces or other unstable places.
 - Poorly ventilated spaces.
 - Near a radiator, other heat sources, or in direct sunshine.
 - Continual vibration areas.
 - Humid, dusty, steamy, or oily areas.
 - An environment where there are corrosive gases (sulfur dioxide, hydrogen sulfide, nitrogen dioxide, chlorine, ammonia, ozone, etc.).
 - Outdoors.
 - High-temperature environment where humidity changes rapidly and condensation is likely to occur.
 - Do not use in places such as those described below where the projector could get wet. Doing so could lead to fire or electric shock.
 - Do not use in the rain or snow, on a seashore or waterfront, etc.
 - Do not use in a bathroom or shower room.
 - Do not install under equipment that discharges water, such as air conditioners.
 - Do not place vases or potted plants on the projector or the AC adapter.
 - Do not place cups, cosmetics or medicines on the projector or the AC adapter.
- Should water, etc. get inside the projector or the AC adapter, first turn off the projector's power, then unplug the power cord from the power outlet and contact your dealer.



CAUTION

Installing suspended from the ceiling

- Consult your dealer for installing the projector on the ceiling. Special skills are required for ceiling installation.
DO NOT perform installation work by people other than installers. Doing so may result in the projector falling and causing injury.
- We are not liable for any accident or/and damage resulting from improper installation or handling, misuse, modification, or natural disasters.
- When installed suspended from the ceiling, etc. do not hang from the projector. The projector could drop and cause injury.
- When installing suspended from the ceiling, use a power outlet that is within reach so the power cord can be easily plugged and unplugged.

⚠ WARNING

On use



PROHIBITED



UNPLUG THE POWER CORD

Do not place objects inside the projector.

- Do not insert or drop metal or combustible objects or other foreign materials into the projector from the vents. Doing so could lead to fire or electric shock. Be particularly careful if there are children in the home. Should a foreign object get inside the projector, first turn off the projector's power, then unplug the power cord from the power outlet and contact your dealer.



UNPLUG THE POWER CORD

Unplug the power cord if the projector malfunctions.

- Should the projector or the AC adapter emit smoke or strange odors or sounds, or if the projector or the AC adapter has been dropped or the cabinet broken, turn off the projector's power, then unplug the power cord from the power outlet. It may cause not only fire or electric shock but also serious damage to your eyesight or burns. Contact your dealer for repairs. Never try to repair the projector on your own. Doing so is dangerous.



DO NOT DISASSEMBLE

Do not disassemble the projector or the AC adapter.

- Do not remove or open the projector's cabinet or the AC adapter. Also, do not modify the projector or the AC adapter. There are high voltage areas in the projector and the AC adapter. It may cause fire, electric shock, or laser light leakage, resulting in serious damage to your eyesight or burns. Have qualified service personnel perform inspection, adjustments and repairs of the interior.



PROHIBITED



CAUTION FOR HIGH TEMPERATURE

Do not place objects in front of the lens while the projector is operating.

- Do not leave the lens cap on the lens while the projector is operating. The lens cap could get hot and be warped.
- Do not place objects in front of the lens that obstruct the light while the projector is operating. The object could get hot and be broken or catch fire.
- The below pictogram indicated on the cabinet means the precaution for avoiding to place objects in front of the projector lens.



PROHIBITED

When cleaning the projector

- Do not use flammable gas sprays to remove dust from the lens, cabinet, etc. Doing so could lead to fire.



PROHIBITED

Do not use in high security locations.

- Usage of the product must not be accompanied by fatal risks or dangers that, could lead directly to death, personal injury, severe physical damage or other loss, including nuclear reaction control in nuclear facility, medical life support system, and missile launch control in a weapon system.

CAUTION

Power cord



REQUIRED

Handling the AC adapter and the power cord

- The projector should be installed close to an easily accessible power outlet.
- When connecting the AC adapter to the projector's DC IN terminal and connecting the power cord to the AC adapter and the power outlet, make sure the connector is fully and firmly inserted. Loose connection of the power cord could lead to fire or electric shock.



REQUIRED

Periodically clean dust and other debris from the power plug

- Failure to do so could result in fire or electric shock.



REQUIRED



UNPLUG THE
POWER CORD

Handling the power cord by following below to avoid fire or electric shock

- When connecting or disconnecting the power cord, pull the power cord out by holding onto its plug.
- Unplug the power cord from the power outlet before cleaning the product or when not planning to use the product for an extended time.
- When the power cord or plug is heat or damaged, unplug the power cord from the power outlet, and contact your dealer.



REQUIRED

Disconnect power cords and other cables before moving the projector

- Before moving the product, make sure the product power is off, then unplug the power cord from the power outlet and check that all cables connecting the product to other devices are disconnected.



PROHIBITED

Do not use the power cord with a power tap

- Adding an extension cord may lead to fire as a result of overheating.

AC adapter



PROHIBITED

Do not touch the AC adapter for long periods

- Do not touch the AC adapter for long periods of time during or after using the projector. It may cause burns.
- After turning off the projector, wait about 30 minutes before touching the AC adapter.

On use









REQUIRED

Focus and zoom operations

- When adjusting the focus or zoom, do so from either behind or to the side of the projector. If these operations are performed from the front, your eyes could be exposed to strong light and get injured.

CAUTION

 PROHIBITED	Handling batteries <p>Incorrect usage of batteries can result in leaks or bursting.</p> <ul style="list-style-type: none">• Use the specified batteries only.• Insert batteries matching the (+) and (–) signs on each battery to the (+) and (–) signs of the battery compartment.• Do not mix battery brands.• Do not combine new and old batteries. This can shorten battery life or cause liquid leakage of batteries.• Remove dead batteries immediately to prevent battery acid from leaking into the battery compartment. <p>If leaked battery fluid gets on your skin or clothing, rinse immediately and thoroughly. If it gets into your eye, bathe your eye well rather than rubbing and seek medical treatment immediately. Leaked battery fluid that gets into your eye or your clothing may cause a skin irritation or damage your eye.</p> <ul style="list-style-type: none">• If you will not use the remote control for a long time, remove the batteries.• Leaving a battery in an extremely high temperature surrounding environment, or a battery subject to extremely low air pressure, that can result in an explosion or the leakage of flammable liquid or gas.
 PROHIBITED	<ul style="list-style-type: none">• Properly dispose of depleted batteries. Disposal of a battery into water, fire, or a hot oven, or mechanically crushing, cutting, or modifying a battery can result in an explosion.• Do not short-circuit the batteries.• Do not charge the batteries. The batteries provided are not rechargeable.• Contact your dealer or local authorities when disposing of batteries.
 PROHIBITED  CAUTION FOR HIGH TEMPERATURE	About the vents <ul style="list-style-type: none">• Do not obstruct the projector’s vents. Also, do not place such soft objects as paper or cloths underneath the projector. Doing so could lead to fire. <p>Leave sufficient space between the place where the projector is installed and its surroundings (as a general rule, at least 30 cm/12 inches for the intake vent, 30 cm/12 inches for the exhaust vent).</p> <ul style="list-style-type: none">• Do not touch the exhaust vent area while projecting or immediately after projecting images. The exhaust vent area may be hot at this time and touching it could cause burns.
 PROHIBITED	Moving the projector <ul style="list-style-type: none">• When moving the projector, do not hold the lens section. The focus ring could turn, causing the projector to drop and resulting in injury.
 REQUIRED	Health precautions to users viewing 3D images <p>Before viewing, be sure to read health care precautions that may be found in the user’s manual included with your 3D eyeglasses or your 3D compatible content such as Blu-ray Discs, video games, computer’s video files and the like.</p> To avoid any adverse symptoms, heed the following: <ul style="list-style-type: none">• Do not use 3D eyeglasses for viewing any material other than 3D images.• Allow a distance of 2 m/7 feet or greater between the screen and a user. Viewing 3D images from too close a distance can strain your eyes.• Avoid viewing 3D images for a prolonged period of time. Take a break of 15 minutes or longer after every hour of viewing.• If you or any member of your family has a history of light-sensitive seizures, consult a doctor before viewing 3D images.• While viewing 3D images, if you get sick such as nausea, dizziness, queasiness, headache, eyestrain, blurry vision, convulsions, and numbness, stop viewing them. If symptoms still persist, consult a doctor.• View 3D images from the front of the screen. Viewing from an angle may cause fatigue or eyestrain.

 **CAUTION**



REQUIRED

Avoid locations with extreme temperatures and humidity

- Failure to do so could lead to fire or electric shock or damage to the projector.
The usage environment for this projector is as follows:
 - The operating temperature: 0 °C to 40 °C / 32°F to 104°F / humidity: 20 to 80% (without condensation)
 - The storage temperature: -10 °C to 50 °C / 14°F to 122°F / humidity: 20 to 80% (without condensation)

Inspections and Cleaning



REQUIRED

Inspecting the projector and cleaning the inside

- Consult with your dealer about once per year for cleaning of the inside of the projector. Dust could accumulate inside of the projector if it is not cleaned for extended periods of time, leading to fires or malfunction.

Notes on installation and maintenance

Do not install or store in such places as those described below.

- Locations that amplify vibrations and impacts
If installed in places where the vibrations from power sources and the like are conveyed, or in vehicles or on vessels, etc. the projector could be affected by vibrations or shocks that may damage internal parts and lead to malfunction.
- Close to high voltage power lines and power sources
It could disrupt the unit.
- Places where strong magnetic fields are generated
Doing so could lead to malfunction.
- Outdoors and places with humid or dust
Places exposed to oil smoke or steam
Places where corrosive gases are generated
Attached substances such as oil, chemicals and moisture may cause deformation or cracks of the cabinet, corrosion of the metal parts, or malfunction.

To the dealer and the installer

1. To prevent the projector from falling, install it on the ceiling in a way with sufficient strength to withstand the combined weight of the projector and the ceiling mount unit for an extended period of time.
2. When installing the projector on the ceiling, be sure to do so correctly in accordance with the installation manual for the Ceiling Mount Unit. Be sure to use the fixed metal fittings and to tighten the screws securely.
3. To prevent the projector from falling, use fall prevention wires.
 - Use commercially available metal fittings to join the robust part of a building or construction and the security bar of the projector with the fall prevention wires.
 - Use commercially available metal fittings and fall prevention wires that have sufficient strength to withstand the combined weight of the projector and the ceiling mount unit.
 - Slightly slack off the fall prevention wires so as not to put a load on the projector.
 - Refer to the “**Product Overview**” for the location of the Security Chain Opening. (→ page 2)

Disposing of your used product

If you wish to dispose of used electrical and electronic products, please contact your local authority and ask for the correct method of disposal.

Securing personal information

Personally identifiable information, such as Security password, may be saved on the projector.

Before transferring or disposing of the projector, clear this data by performing [Setup] → [Reset] on the on-screen menu.

Cautions for ensuring the projector's performance

- If intense light like laser beams enters from the lens, it could lead to malfunction.
- Consult your dealer before using in places where much cigarette smoke or dust is present.
- When the projector is used at high altitudes (places where the atmospheric pressure is low), it may be necessary to replace the optical parts sooner than usual.
- About moving the projector
 - Be sure to attach the lens cap so as not to scratch the lens.
 - Do not subject the projector to vibrations or strong shocks.
The projector could be damaged otherwise.
- Do not use the tilt feet for purposes other than adjusting the projector's tilt.
Improper handling, such as carrying the projector by the tilt feet or using it leaned against a wall, could lead to malfunction.
- The projector does not support stack installation. Do not stack projectors directly on top of each other. Failure to do so may cause damage or failure.
- Do not touch the surface of the projection lens with bare hands.
Fingerprints or dirt on the surface of the projection lens will be enlarged and projected on the screen. Do not touch the surface of the projection lens.
- Do not unplug the power cord from the projector or the power outlet while projecting. It could lead to malfunction.

- About handling of the remote control
 - The remote control will not work if the projector's remote signal sensor or the remote control's signal transmitter is exposed to strong light or if there are obstacles between them that obstruct the signals.
 - Operate the remote control from within 6 meters (19.7 feet) from the projector, pointing it at the projector's remote signal sensor.
 - Do not drop the remote control or handle it improperly.
 - Do not let water or other liquids get on the remote control. Should the remote control get wet, wipe it off immediately.
 - Avoid using in hot and humid places as far as possible.
- Take measures to prevent external light from shining on the screen.

Make sure only the light from the projector shines on the screen. The less external light on the screen, the higher the contrast and the more beautiful the images.
- About screens

Images will not be clear if there is dirt, scratches, discoloration, etc. on your screen. Handle the screen with care, protecting it from volatile substances, scratches and dirt.

Clearance for Installing the Projector

When installing the projector, keep sufficient space around it, as described below. If not, the hot exhaust emitted from the projector may be taken back in.

Also, make sure no wind from an air-conditioner hits the projector.

The projector's heat control system may detect an abnormality (temperature error) and automatically shut off the power.

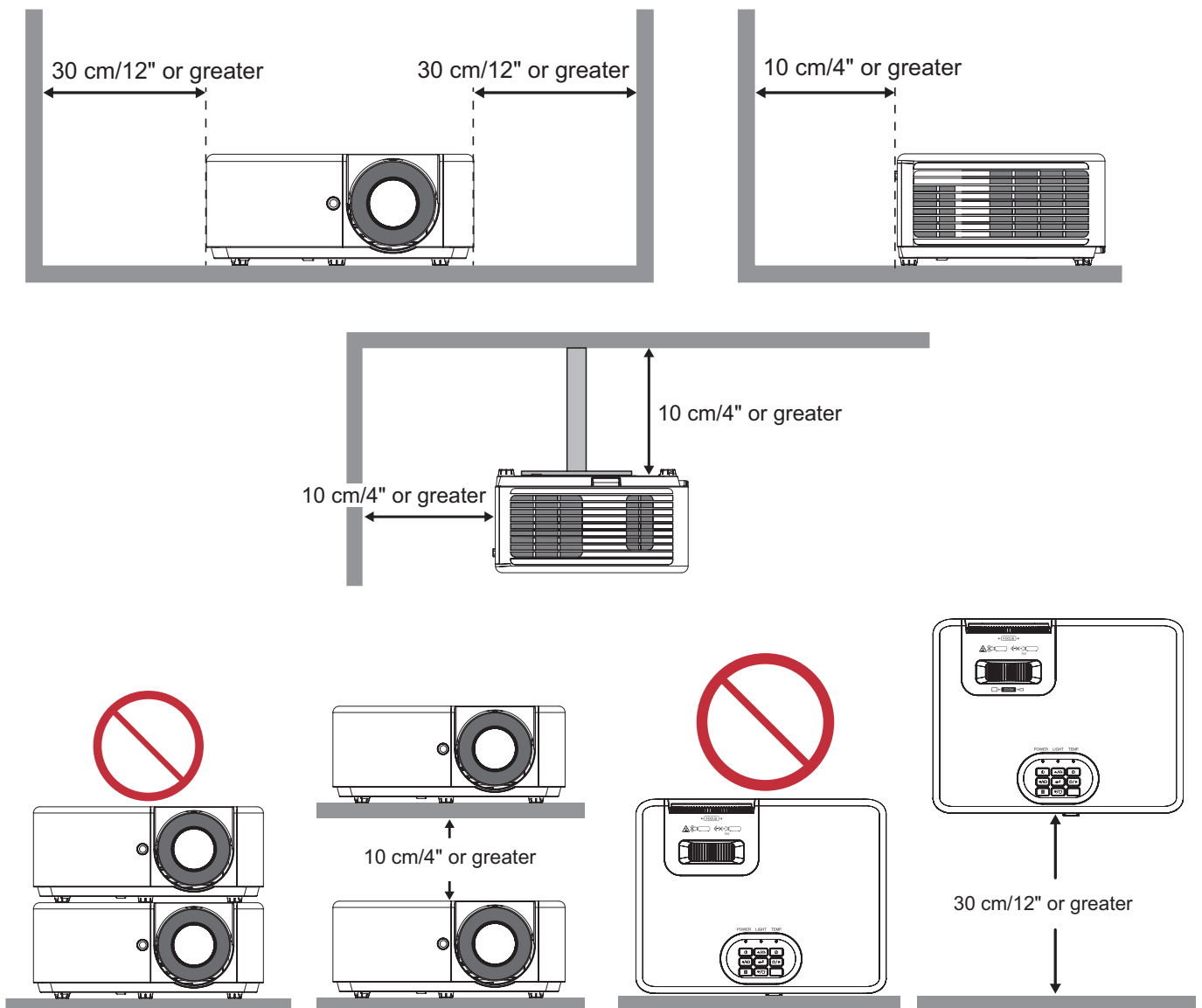

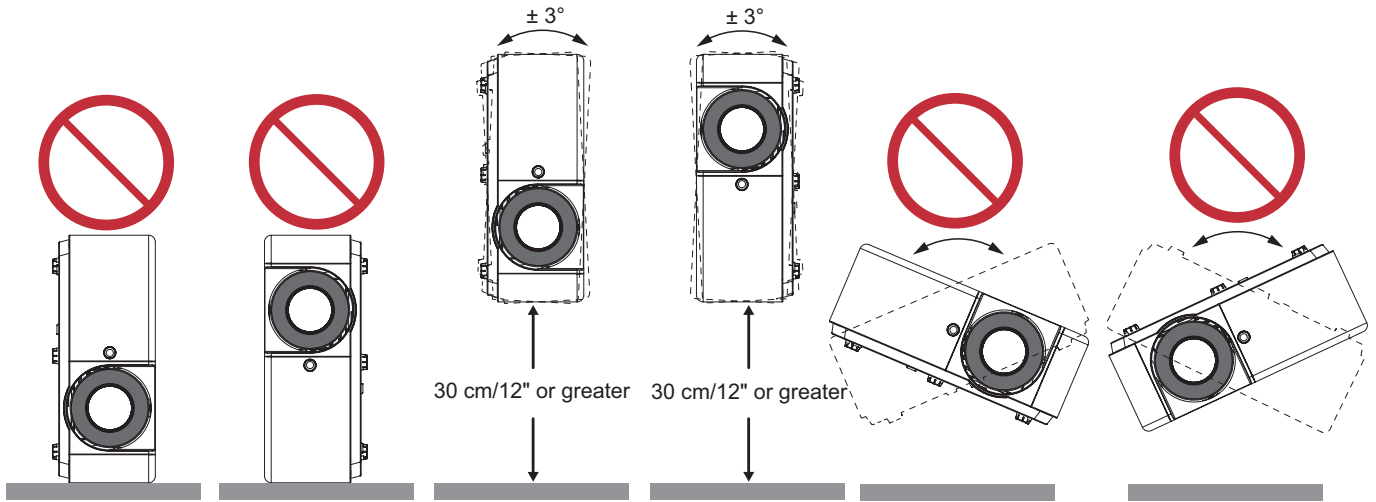

AC adapter notice

Place the AC adapter at least 30 cm away from the projector.

If the heat from the projector causes the AC adapter to become hot, the projector may not operate properly.

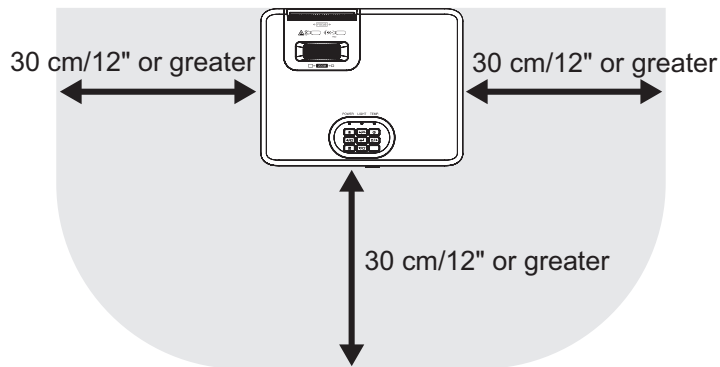

About Copyright of original projected pictures

Please note that using this projector for the purpose of commercial gain or the attraction of public attention in a venue such as a coffee shop or hotel and employing compression or expansion of the screen image with the following functions may raise concern about the infringement of copyrights which are protected by copyright law.

[Aspect Ratio], [Keystone], Magnifying feature and other similar features.

[Auto Power Off] Function

The factory default setting for [Auto Power Off] is 15 minutes. If no input signal is received and no operation is performed on the projector during 15 minutes, the projector is automatically powered off for saving the power consumption. In order to control the projector by an external device, set the [Auto Power Off] to [0]. Please refer page 28 for details.

Trademarks

- DLP®, DLP logo, and BrilliantColor™ are trademarks or registered trademarks of Texas Instruments in the United States and other countries.
- The terms HDMI, HDMI High-Definition Multimedia Interface, HDMI Trade dress and the HDMI Logos are trademarks or registered trademarks of HDMI Licensing Administrator, Inc.



- Blu-ray is a trademark of Blu-ray Disc Association.
- Other product and company names mentioned in this user's manual may be the trademarks or registered trademarks of their respective holders.

INTRODUCTION

Package Overview

Carefully unpack and verify that you have the items listed below under standard accessories. Some of the items under optional accessories may not be available depending on the model, specification and your region of purchase. Please check with your place of purchase. Some accessories may vary from region to region.

The warranty card is only supplied in some specific regions. Please consult your dealer for detailed information.

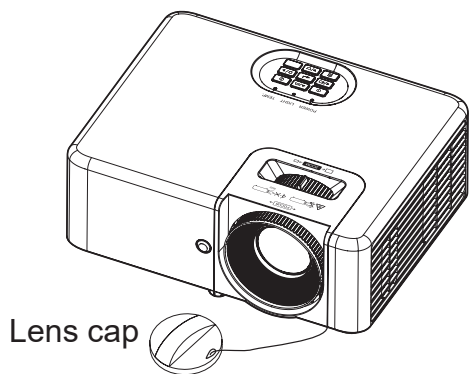

Projector

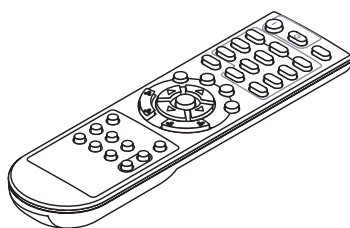

Remote control

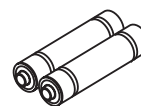

**AAA manganese
batteries (x2)**

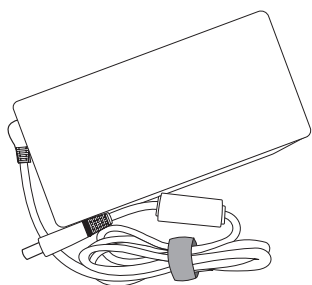

AC adapter

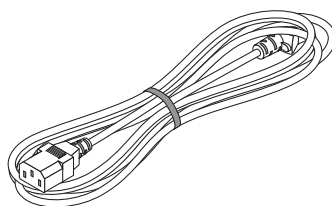

Power cord

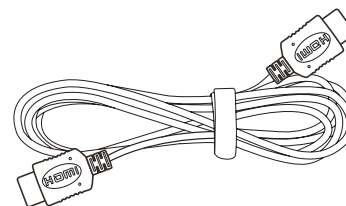

**HDMI cable
0TJM401H00191
(VW00PCO000011)**

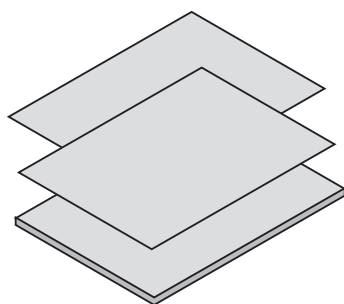

- Important Information
- Quick Setup Guide
- Limited warranty

Product Overview

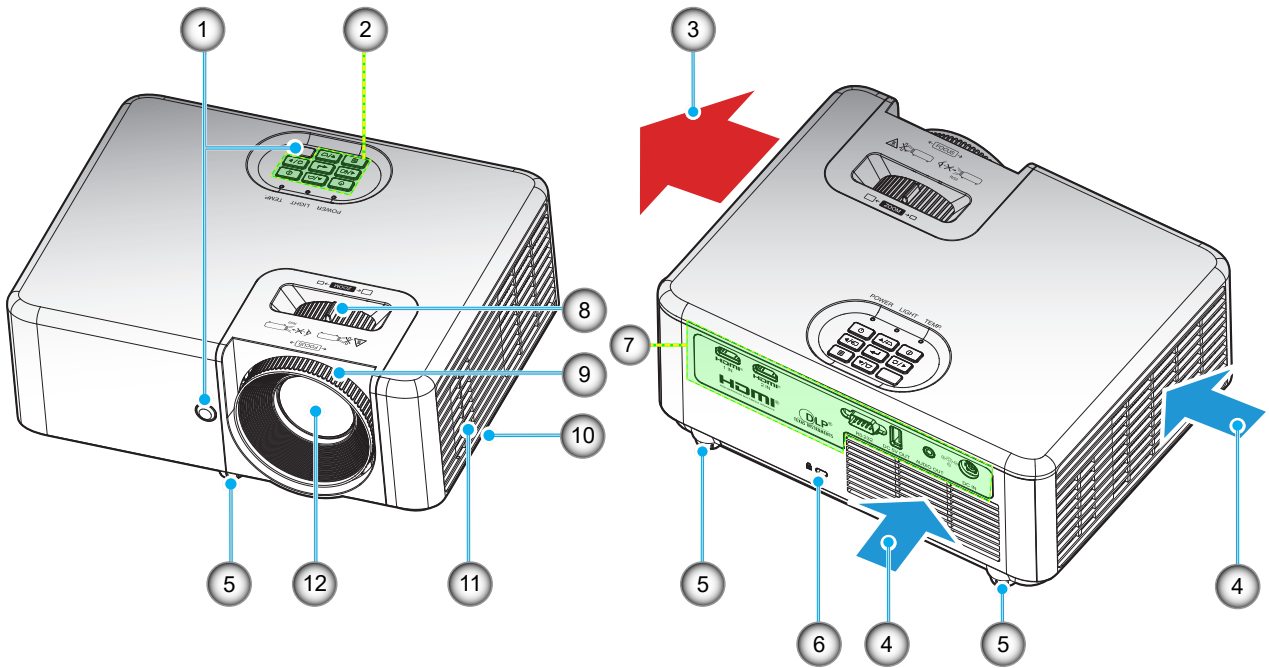



Note:

- Do not block projector intake and exhaust vents.
- When operating the projector in an enclosed space, allow at least 30 cm clearance around the intake and exhaust vents.
- Attach an anti-theft device to the Security chain opening. The security chain opening accepts security wires or chains up to approximately 0.2 inch / 5 mm in diameter.

No	Item	No	Item
1.	IR Receivers	7.	Input / Output
2.	Keypad	8.	Zoom Ring
3.	Ventilation (outlet)	9.	Focus Ring
4.	Ventilation (inlet)	10.	Security Chain Opening
5.	Tilt-Adjustment Feet	11.	Speaker
6.	Kensington™ Lock Port 	12.	Lens

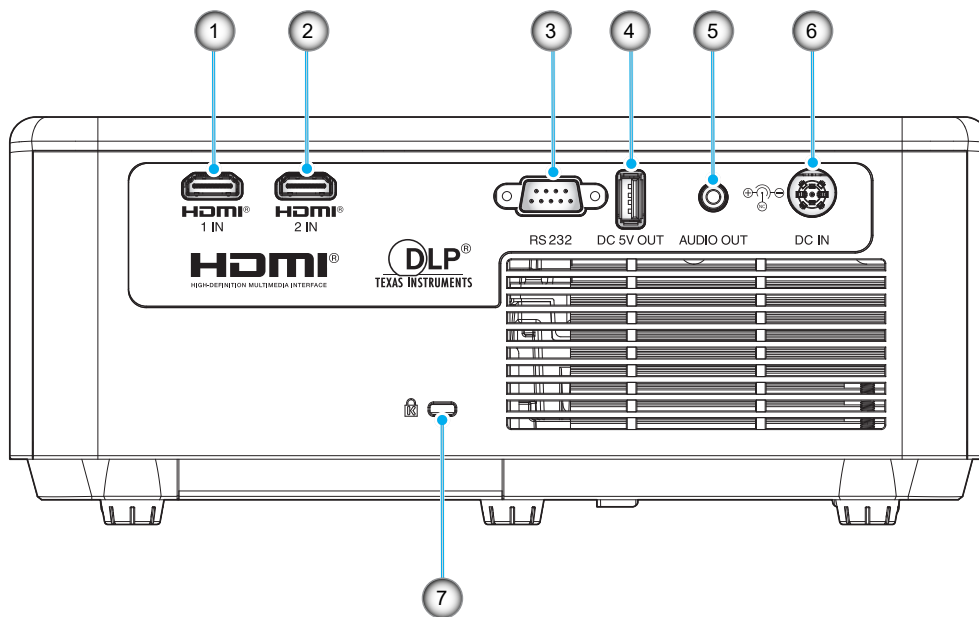
Connections



No	Item	No	Item
	HDMI 1 Connector		
1.	<ul style="list-style-type: none"> • XP-M401H: HDCP 2.2 • XP-M421W: HDCP 1.4 	5.	AUDIO OUT Connector
	HDMI 2 Connector		
2.	<ul style="list-style-type: none"> • XP-M401H: HDCP 1.4 • XP-M421W: HDCP 1.4 	6.	DC IN Connector
3.	RS232 Connector	7.	Kensington™ Lock Port 
4.	USB Power Out (5V $\overline{\text{---}}$ 1.5A) Connector		

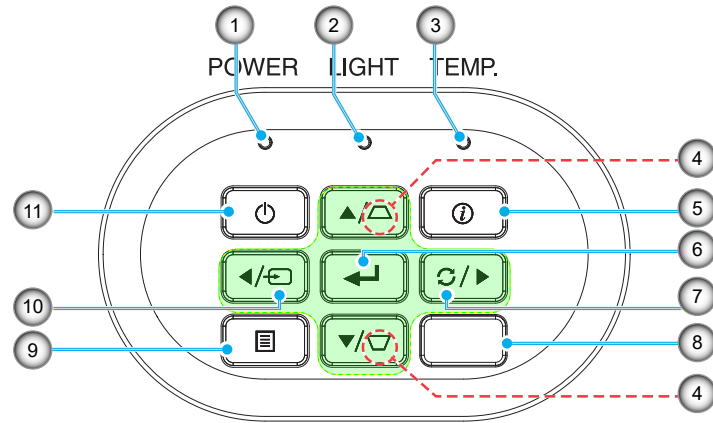

Keypad

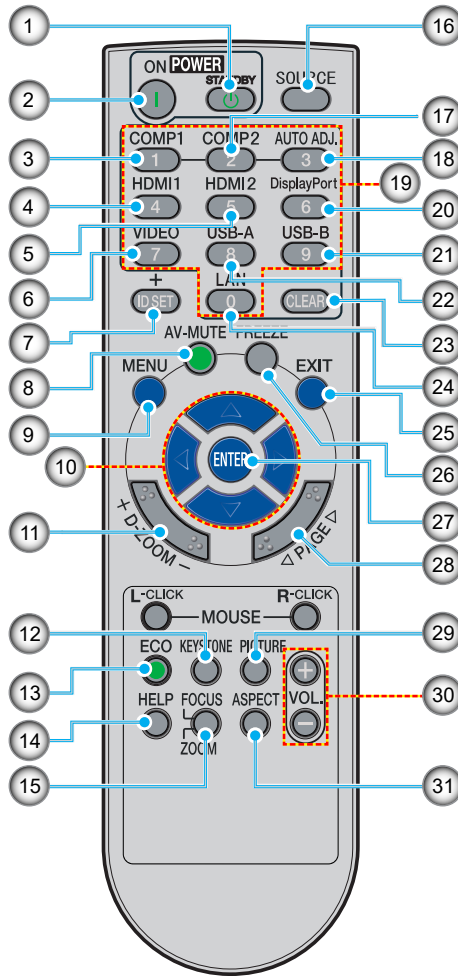

No	Item	No	Item
1.	Power LED	7.	Re-Sync
2.	Light LED	8.	IR Receiver
3.	Temp LED	9.	Menu
4.	Keystone Correction	10.	Source
5.	Information	11.	Power 
6.	Enter		

Remote control



No	Item	Description
1.	STANDBY 	Power off the projector. Please see the “Powering on / off the projector” on page 2315.
2.	ON 	Power on the projector. Please see the “Powering on / off the projector” on page 2315.
3.	COMPUTER 1	No function.
4.	HDMI 1	Press “4” to choose source from HDMI 1 connector.
5.	HDMI 2	Press “5” to choose source from HDMI 2 connector.
6.	VIDEO	No function.
7.	ID SET	No function.
8.	AV-MUTE	Momentarily turn off/on the audio and video.
9.	MENU	Launch the on-screen display (OSD), back to the higher level of OSD for the OSD main menu operation.
10.	Four Directional Select Keys	Use the ▲, ▼, ◀, or ▶ button to select items or make adjustments to your selection.
11.	D-ZOOM	Zoom in/out the projected image.
12.	KEystone Correction	Adjust the image to compensate for distortion caused by tilting the projector.
13.	ECO	Display the Brightness Mode menu.
14.	HELP	Display the Information menu.
15.	FOCUS/ZOOM	No function.
16.	SOURCE	Select the desired input source.
17.	COMPUTER 2	No function.
18.	AUTO ADJ.	Automatically synchronize the projector to the input source.
19.	Number Buttons	No function.

No	Item	Description
20.	DisplayPort	No function.
21.	USB B	No function.
22.	USB A	No function.
23.	CLEAR	No function.
24.	LAN	No function.
25.	EXIT	Back to the higher level of OSD.
26.	FREEZE	Pause the screen image. Press again to resume the screen image.
27.	ENTER	Confirm your section of items in sub menu operation.
28.	PAGE	No function.
29.	PICTURE Mode	Choose your desired display mode. Please see page 21.
30.	VOL. +/-	Increase/decrease speaker volume.
31.	ASPECT	Choose your desired aspect ratio. Please see page 23.

Note: Some keys may have no function for models that do not support these features.

Power cord

The power cord specification:

- AC Input: 123 VAC, 10 A
- Length: 1.8 m (71 inch)

AC adapter

The AC adapter specification:

- AC Input: 100~240 VAC, 3.5 A, 50~60 Hz
- DC Output: 19.5 VDC, 11.79 A
- Length: 1.2 m (47 inch)

Dimensions:

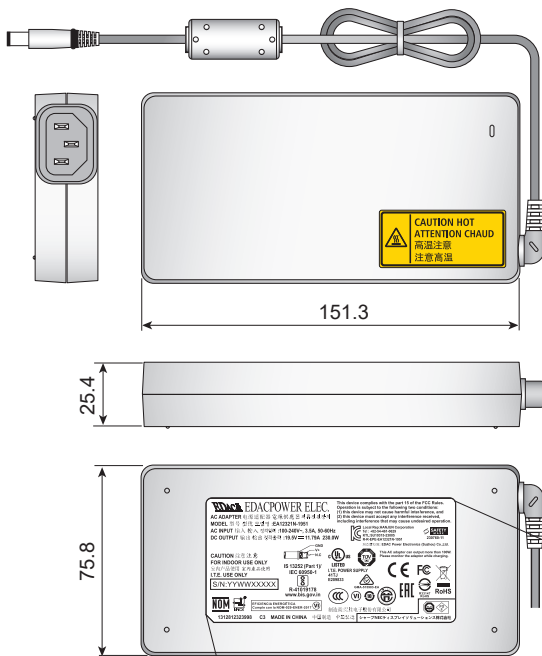

Making connections:

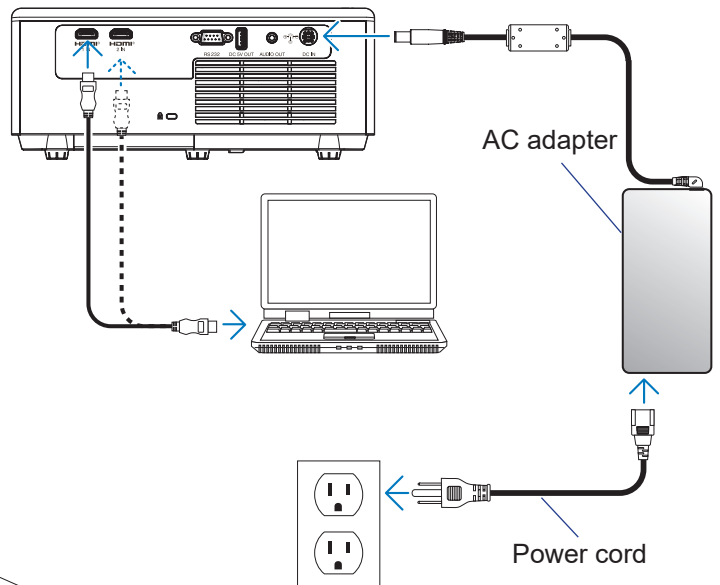

EDAC EDACPOWER ELEC. AC ADAPTER 电源适配器 電源供應器 직류전원장치 MODEL 型号 型号 모델명: EA12321N-1951 AC INPUT 输入 輸入 정격입력 : 100-240V~, 3.5A, 50-60Hz DC OUTPUT 输出 輸出 정격출력 : 19.5V $\overline{\text{---}}$ 11.79A 230.0W		This device complies with the part 15 of the FCC Rules. Operation is subject to the following two conditions: (1) this device may not cause harmful interference, and (2) this device must accept any interference received, including interference that may cause undesired operation.	
CAUTION 注意 注意 FOR INDOOR USE ONLY 室内产品使用 室内产品使用 I.T.E. USE ONLY S/N: YYWWXXXXXX		Local Rep: HANJUN Corporation Tel: +82-54-461-0629 KTL: SU10315-23005 R-R-EPE-EA12321N-1951 제조업자명: EDAC Power Electronics (Suzhou) Co., Ltd.	
IS 13252 (Part 1)/ IEC 60950-1 R-41019178 www.bis.gov.in		This AC adaptor can output more than 100W. Please monitor the adaptor while charging.	
NOM EFICIENCIA ENERGÉTICA Cumple con la NOM-029-ENER-2017		UL LISTED I.T.E. POWER SUPPLY 41TJ E209833	
1312812323998 C3 MADE IN CHINA 中国制造 中國製造		SAFETY MARK 230760-11 CE FC RoHS	
1312812323998 C3 MADE IN CHINA 中国制造 中國製造		制造商: 聖勝电子股份有限公司 シャープNECディスプレイソリューションズ株式会社	

SETUP AND INSTALLATION

Installing the projector

Your projector is designed to be installed in one of four possible positions.

Your room layout or personal preference will dictate which installation location you select. Take into consideration the size and position of your screen, the location of a suitable power outlet, as well as the location and distance between the projector and the rest of your equipment.

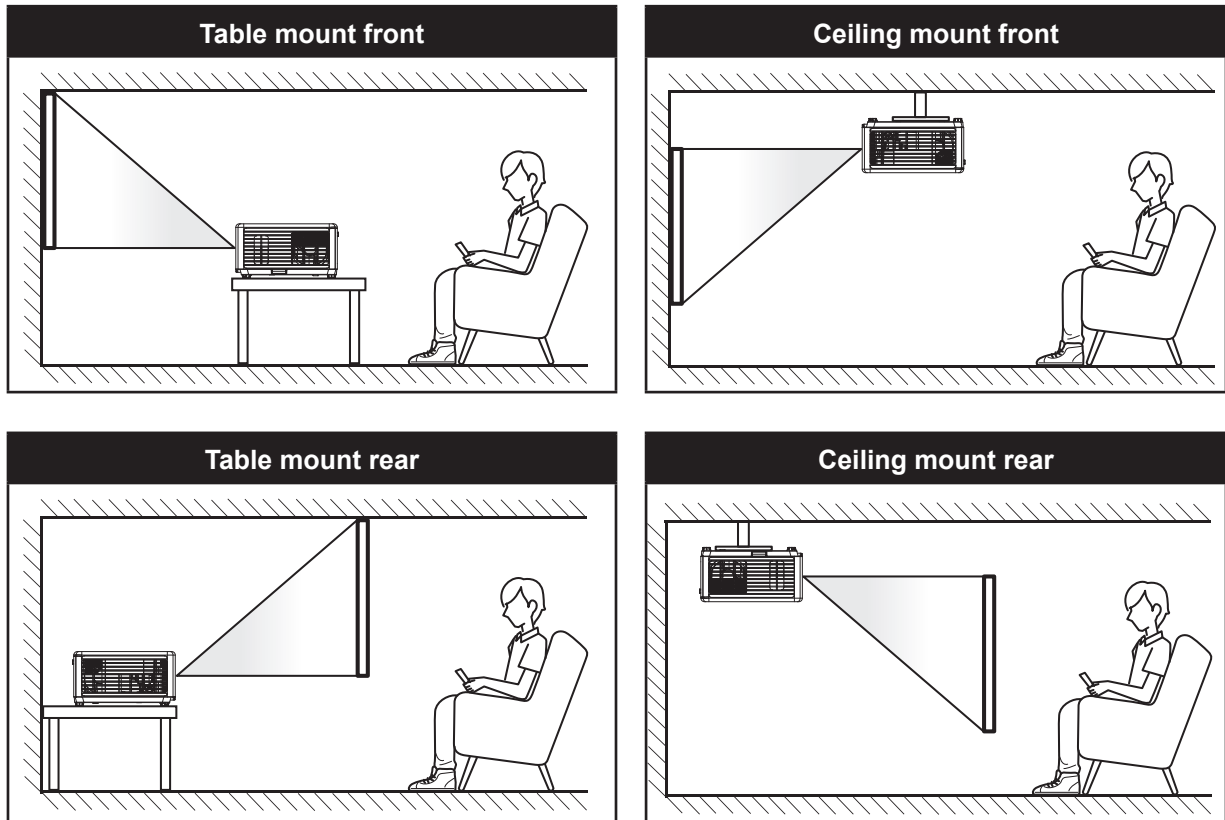

Projector should be placed flat on a surface and 90 degrees / perpendicular to the screen.

- How to determine projector location for a given screen size, please refer to distance table on pages 39-40.
- How to determine screen size for a given distance, please refer to distance table on pages 39-40.

Note: *The further away the projector is placed from the screen the projected image size increases and vertical offset also increases proportionally.*

Connecting to a computer

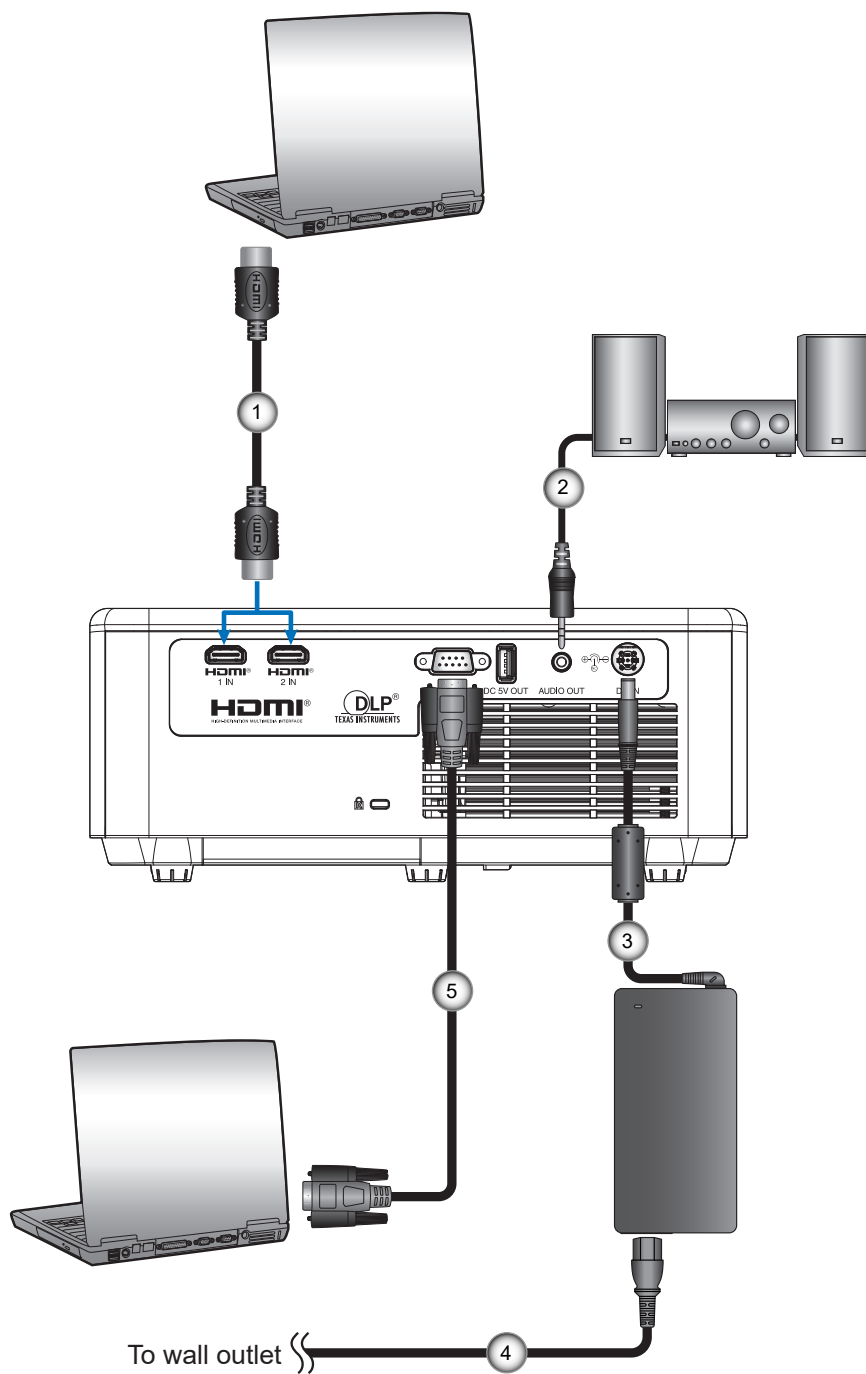

No	Item	No	Item
1.	HDMI Cable	4.	Power Cord
2.	Audio Out Cable	5.	RS232 Cable
3.	DC Jack		

Connecting to a Media player

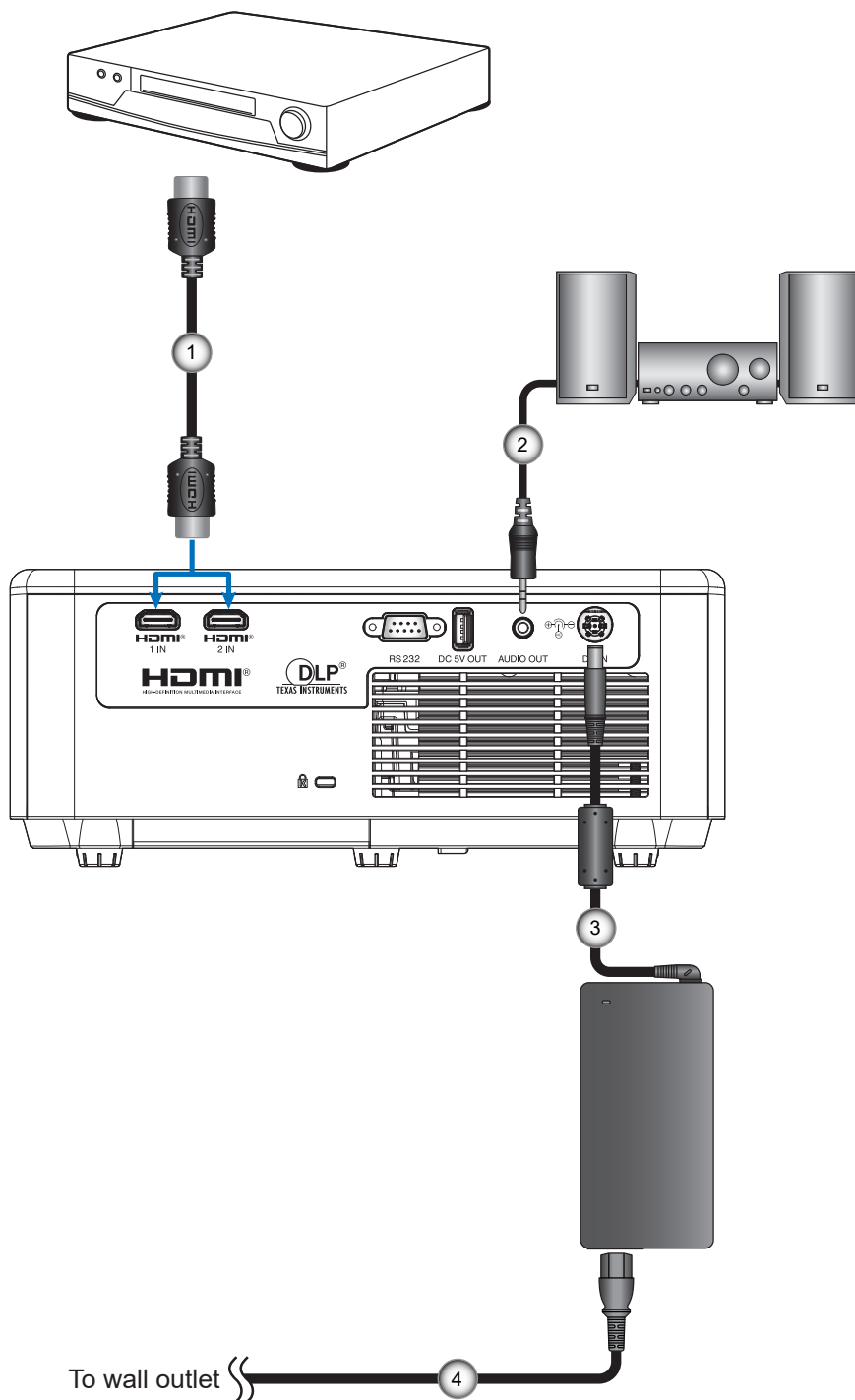

No	Item	No	Item
1.	HDMI Cable	3.	DC Jack
2.	Audio Out Cable	4.	Power Cord

Adjusting the projector image

Image height

The projector is equipped with elevator feet for adjusting the image height.

1. Locate the adjustable foot you wish to adjust on the underside of the projector.
2. Rotate the adjustable foot clockwise or counterclockwise to raise or lower the projector.
The tilt feet can be used to tilt the projector by a maximum of 8°.

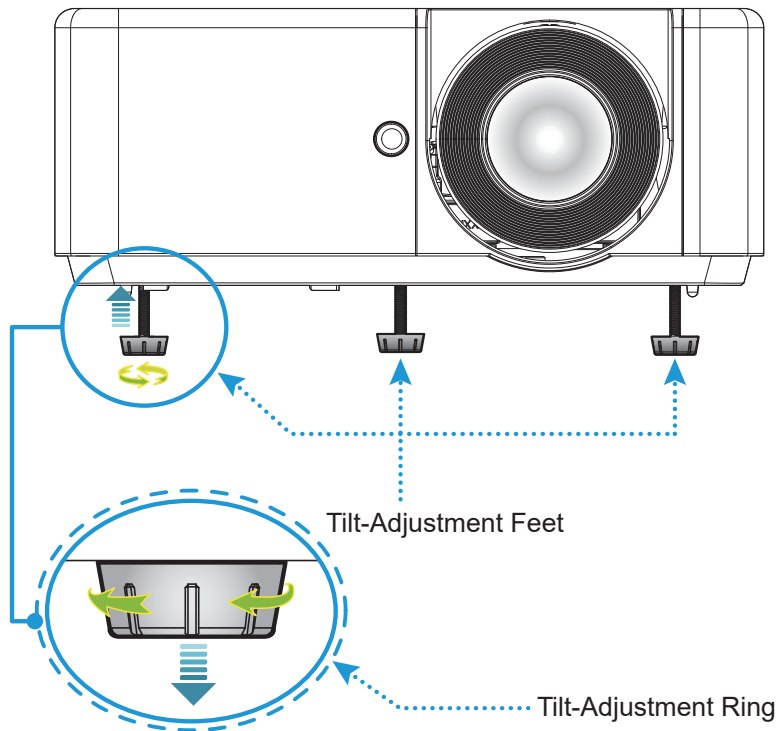

Note:

- Do not lengthen the tilt feet any more than 28 mm/1.1". Doing so will make the tilt feet's mount section unstable and could cause the tilt feet to come off the projector.
- Do not use the tilt feet for any purpose other than adjusting the projector's projection angle. Handling the tilt feet improperly, such as carrying the projector by grasping the tilt feet or hooking it onto a wall using the tilt feet, could damage the projector.

Zoom and focus

- To adjust the image size, turn the zoom ring clockwise or counterclockwise to increase or decrease the projected image size.
- To adjust the focus, turn the focus ring clockwise or counterclockwise until the image is DUKANE and legible.

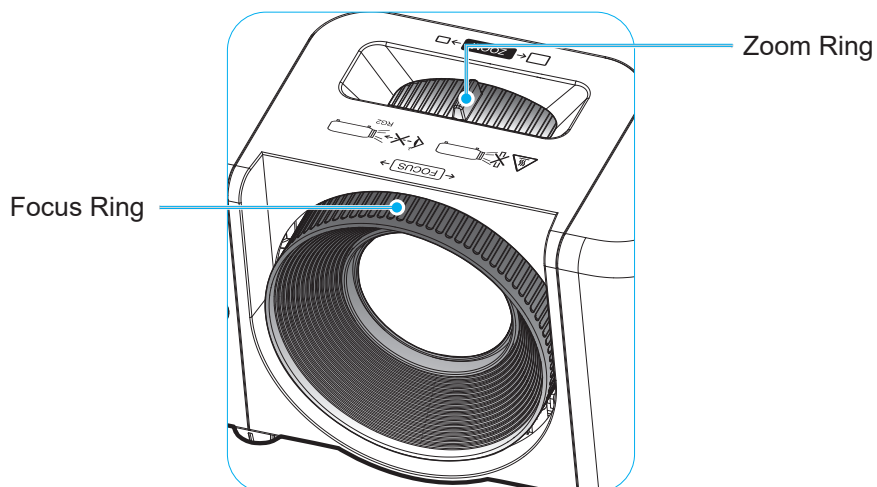

Note: When adjusting the focus, adjust it while looking at the entire projection screen to achieve a good balance. If you focus only on the center of the projection screen, the periphery may become blurred.

Remote setup

Installing / replacing the batteries

Two AAA size manganese batteries are supplied for the remote control.

1. Press firmly and slide the battery cover off.

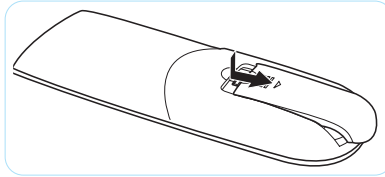

2. Install new batteries (AAA). Ensure that you have the batteries' polarity (+/-) aligned correctly.

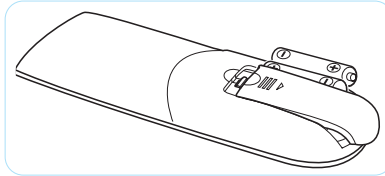

3. Slip the cover back over the batteries until it snaps into place.

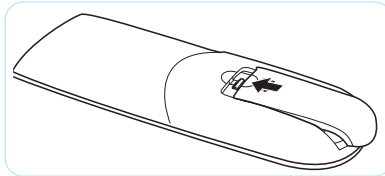

Note: Replace only with the same or equivalent type (alkaline or manganese) batteries.

CAUTION

Improper use of batteries can result in chemical leakage or explosion. Be sure to follow the instructions below.

- Do not mix batteries of different types. Different types of batteries have different characteristics.
- Do not mix old and new batteries. Mixing old and new batteries can shorten the life of new batteries or cause chemical leakage in old batteries.
- Remove batteries as soon as they are depleted. Chemicals that leak from batteries that come in contact with skin can cause a rash. If you find any chemical leakage, wipe thoroughly with a cloth.
- The batteries supplied with this product may have a shorter life expectancy due to storage conditions.
- If you will not be using the remote control for an extended period of time, remove the batteries.
- When you dispose of the batteries, you must obey the law in the relative area or country.

Effective range

Infra-Red (IR) remote control sensor is located in front and on top of the projector. Ensure to hold the remote control at an angle within 30° perpendicular to the projector's IR remote control sensors to function correctly. The distance between the remote control and the sensor should not be longer than 6 meters (~19 feet).

Note: When pointing the remote control directly (0 degrees angle) on the IR sensor, the distance between the remote control and the sensor should not be longer than 8 meters (~26 feet).

- Make sure that there are no obstacles between the remote control and the IR sensor on the projector that might obstruct the infra-red beam.
- Make sure the IR transmitter of the remote control is not being shined by sunlight or fluorescent lamps directly.
- Please keep the remote controller away from fluorescent lamps for over 2 m or the remote controller might become malfunction.
- If the remote control is close to Inverter-Type fluorescent lamps, it might become ineffective from time to time.
- If the remote control and the projector are within a very short distance, the remote control might become ineffective.
- When you aim at the screen, the effective distance is less than 5 m from the remote control to the screen and reflecting the IR beams back to the projector. However, the effective range might change according to screens.

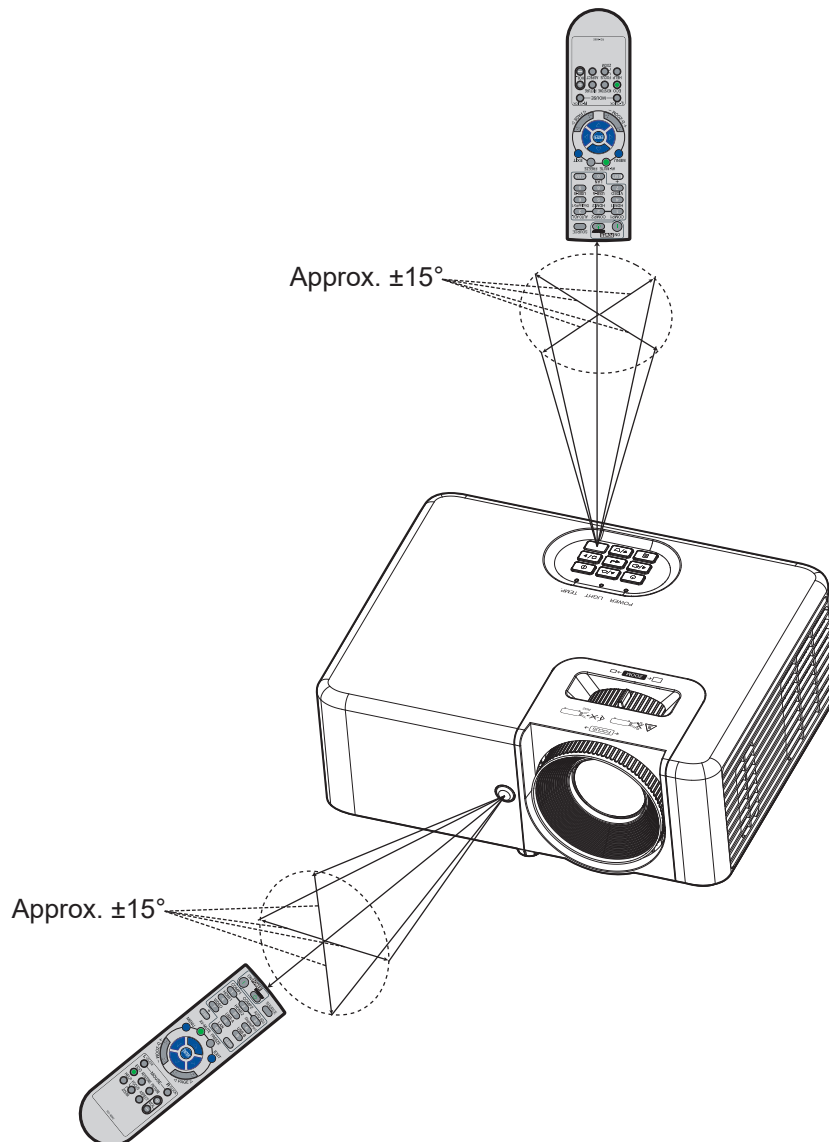

USING THE PROJECTOR

Powering on / off the projector

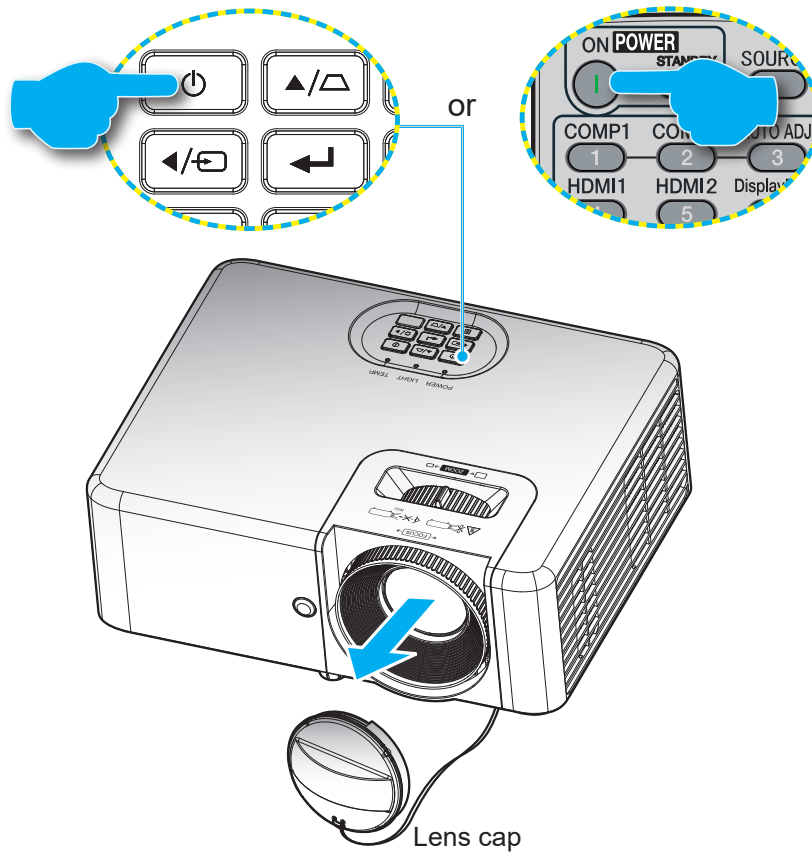

Powering on

1. Remove the lens cap.
2. Securely connect the signal/source cables. Then connect the power lead to the adaptor and the adaptor to the projector. When connected, the Power LED will turn red.
3. Turn on the projector by pressing the \cup button on the projector keypad or remote control.
4. After approximately 10 seconds the Power LED will turn blue.

Note: The first time the projector is turned on, you will be prompted to select the preferred language, projection orientation, and other settings.



CAUTION

- Do not touch the AC adaptor for long periods of time during or after using the projector. It may cause burns.
- After turning off the projector, wait about 30 minutes before touching the AC adaptor.

Powering off

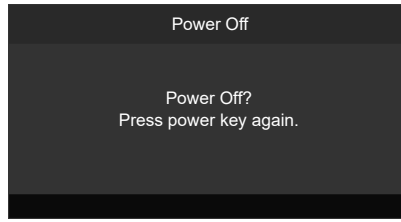
1. Turn off the projector by pressing the  button on the projector keypad or remote control.
2. The following message will be displayed:



3. Press the  button again to confirm, otherwise the message will disappear after 10 seconds. When you press the  button for the second time, the projector will shut down.
4. When the Power turns solid red, this indicates the projector has entered standby mode. If you wish to turn the projector back on, you must wait until the cooling cycle has finished and the projector has entered standby mode. When the projector is in standby mode, simply press the **Power On** button again to turn on the projector.
5. Disconnect the power lead from the electrical outlet and the projector.

Note: It is not recommended that the projector is turned on immediately, right after a power off procedure.

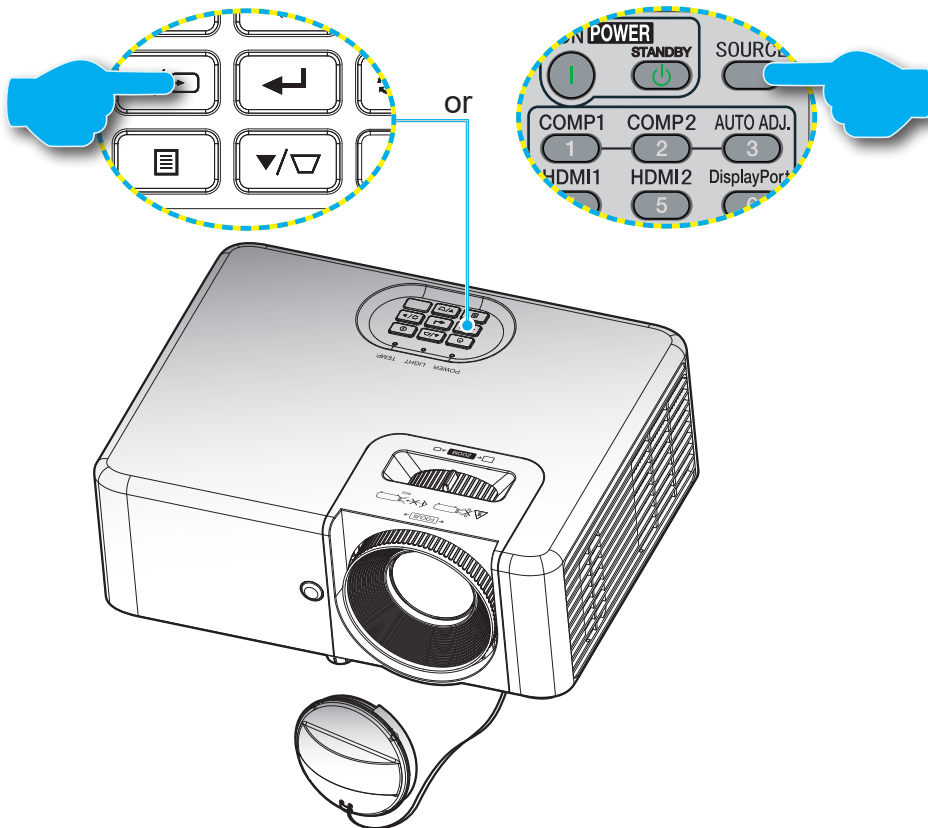

Selecting an input source

Turn on the connected source such as a computer, Blu-Ray player, etc. Press the  button on the keypad or the **Source** button on the remote control.



Menu navigation and features

The projector has multilingual on screen display menus that allow you to make image adjustments and change a variety of settings.

1. To open the OSD menu, press the  button on the projector keypad or the **Menu** button on the remote control.
2. When OSD is displayed, use **▲▼** keys to select any item in the main menu. While making a selection on a particular page, press the **←** button on the projector keypad or the **Enter** button on the remote control to enter the sub menu.
3. Use **◀▶** keys to select the desired item in the sub menu and then press the **←** or **Enter** button to view further settings. Adjust the settings by using **◀▶** keys.
4. Select the next item to be adjusted in the sub menu and adjust as described above.
5. Press press the **←** or **Enter** button to confirm, and the screen will return to the main menu.
6. To exit, press the  or **Menu** button again. The OSD menu will close and the projector will automatically save the new settings.

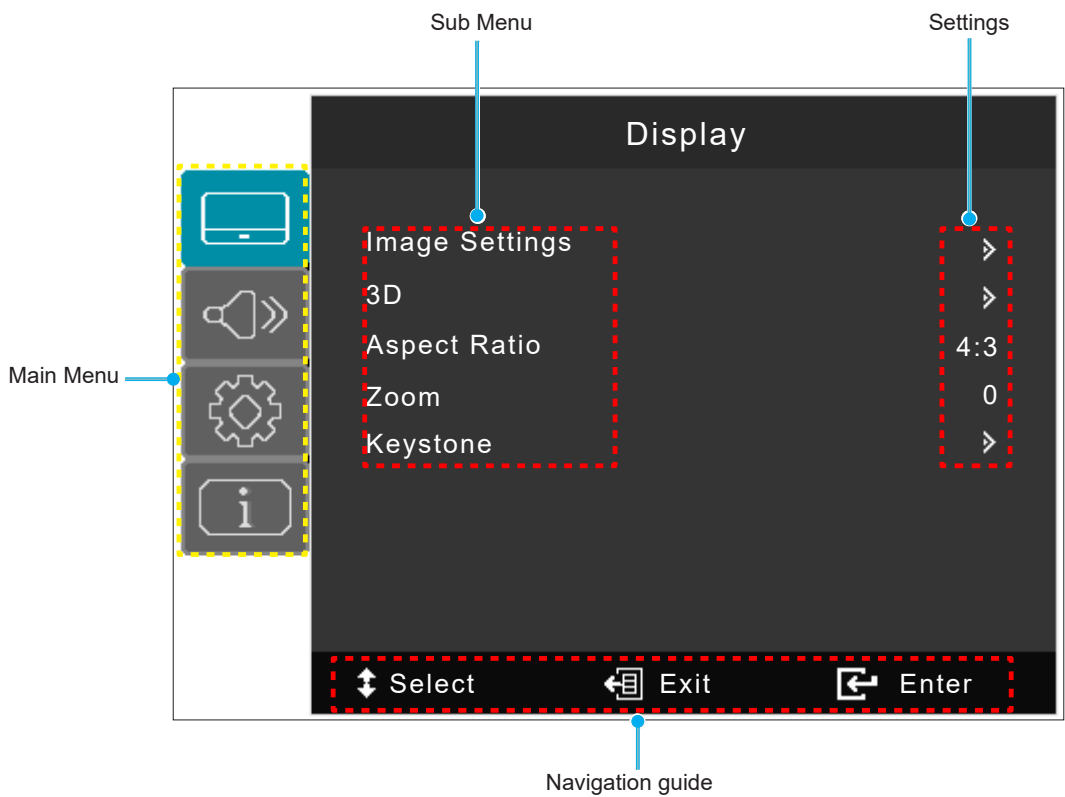

OSD Menu tree

Main Menu	Sub Menu	Sub Menu 2	Sub Menu 3	Sub Menu 4	Values	Factory Default			
Display	Image Settings	Display Mode			Presentation				
					HDR/HLG SIM. Note: Supported only by the 6540HL model.				
					Cinema				
					Sport				
					High-bright				
					User				
				3D					
		Brightness				-50 ~ 50			
		Contrast				-50 ~ 50			
		Sharpness				1 ~ 15			
		Color				-50 ~ 50			
		Tint				-50 ~ 50			
		Gamma				Film			
						Video			
						Graphics			
						Standard(2.2)			
		Color Settings	BrilliantColor™				1 ~ 10		
				Color Temperature			Warm		
						Standard			
						Cold			
			Color Correction	Color			Red / Green / Blue / Cyan / Yellow / Magenta / White (*)		
					Hue / R (*)			-50 ~ 50	
					Saturation G (*)			-50 ~ 50	
					Gain / B (*)			-50 ~ 50	
				Reset					
			Exit						
		Color Space	(HDMI signal)			Auto	Auto		
						RGB(0~255)			
						RGB(16~235)			
						YUV			
	Brightness Mode				DynamicBlack				
					Eco.				
					Power 100% ~ 40%	Power 100%			
	Reset								
	3D	3D Mode				Off	Off		
						On			
		3D Format				Auto	Auto		
						SBS			
						Top and Bottom			
		3D Sync Invert				Frame Sequential			
				Off	Off				
				On					

Main Menu	Sub Menu	Sub Menu 2	Sub Menu 3	Sub Menu 4	Values	Factory Default		
Display	Aspect Ratio				Auto	Auto		
					4:3			
					16:9			
					Full			
					L. Box			
	Zoom				-5 ~ 25	0		
	Keystone	Four Corners						
		H Keystone				-30 ~ 30	0	
		V Keystone				-30 ~ 30	0	
		Auto Keystone				Off	Off	
					On			
Reset								
Audio	Mute				Off	Off		
					On			
	Volume				0 ~ 10	5		
Setup	Projection				Front	Front		
					Rear			
	Projection Location				Auto	Auto		
					Desktop			
					Ceiling			
	Power Settings	Auto Power On	AC Power On			Off	Off	
						On		
		HDMI Power On				Off	Off	
						On		
	Auto Shutdown (min.)				0 ~ 180	15		
	Security	Security				Off	Off	
						On		
		Security Timer	Month				0 ~ 12	0
			Day				0 ~ 30	0
			Hour				0 ~ 24	0
	Change Password					1234		
	HDMI CEC					Off	Off	
						On		
	Test Pattern					Green Grid	Off	
						Magenta Grid		
						White Grid		
						White		
					Off			
Options	Language				English	English		
					Deutsch			
					Français			
					Italiano			
					Español			
					Português			
					Polski			
					Nederlands			
					Svenska			
					Norsk/Dansk			
			Suomi					
				繁體中文				

Main Menu	Sub Menu	Sub Menu 2	Sub Menu 3	Sub Menu 4	Values	Factory Default
Setup	Options	Language			简体中文	English
					日本語	
					한국어	
					Русский	
					Magyar	
					Čeština	
					عربي	
					ไทย	
					Türkçe	
					Tiếng Việt	
			Bahasa Indonesia			
		Auto Source			Off	Off
					On	
		High Altitude			Off	Off
				On		
	Reset			No	No	
				Yes		
Info	Serial Number					
	Source					
	Resolution					
	Refresh Rate					
	Display Mode					
	Light Source Hours					
	Brightness Mode					
	FW Version	System				
	MCU					

Note: Functions vary depending on model definition.

Display menu

Display image settings menu

Display Mode

There are many factory presets optimized for various types of images.

- **Presentation:** This mode is suitable for showing in front of public in connection to the PC.
- **HDR/HLG SIM.:** Decodes and displays High Dynamic Range (HDR) / Hybrid Log Gamma (HLG) content for the deepest blacks, brightest whites, and vivid cinematic color using REC.2020 color gamut.
This mode will be automatically enabled if HDR/HLG is set to Auto (and HDR/HLG Content is sent to projector – 4K UHD Blu-ray, 1080p/4K UHD HDR/HLG Games, 4K UHD Streaming Video).
Note: *HDR/HLG SIM. is supported only by the 6540HL model only.*
- **Cinema:** Provides the best colors for watching movies.
- **Sport:** Select this mode to increase brightness and decrease response time for watching football.
- **High-bright:** Maximum brightness from any source.
Note: *The life of the optical components may also be shortened depending on the operating environment.*
- **User:** Saved user's settings.
- **3D:** To experience 3D you need DLP-Link 3D glasses and video source capable of sending 3D content.

Brightness

Adjust the brightness of the image.

Contrast

The contrast controls the degree of difference between the lightest and darkest parts of the picture.

Sharpness

Adjust the Sharpness of a Video source.

Color

Adjust a Video source from black and white to fully saturated color.

Tint

Adjust the color balance of a Video source between red and green.

Gamma

Set up gamma curve type. After the initial setup and fine tuning is completed, utilize the Gamma Adjustment steps to optimize your image output.

- **Film:** For home theater.
- **Video:** For video or TV source.
- **Graphics:** For PC / Photo source.
- **Standard (2.2):** For standardized setting.

Note:

- *These options are only available if the 3D mode function is disabled, the **Wall Color** setting is not set to **Blackboard**, and the **Display Mode** setting is not set to **HDR/HLG SIM.***
- *In 3D mode, user can only select **3D** for **Gamma** setting.*
- *If the **Display Mode** setting is set to **HDR SIM.**, user can only select **HDR SIM.** for **Gamma** setting.*

Color Settings

Configure the color settings.

- **BrilliantColor™**: This adjustable item utilizes a new color-processing algorithm and enhancements to enable higher brightness while providing true, more vibrant colors in picture.
- **Color Temperature**: Select a color temperature from Warm, Standard, or Cold.
Note: *If the display mode is set to Cinema, you cannot set the color temperature.*
- **Color Correction**: Select the following options:
 - Color: Adjust the red, green, blue, cyan, yellow, magenta, and white level of the image.
 - Hue / R(red)*: Adjust the color balance of red and green.
Note: **If the **Color** setting is set to **White**, you can adjust the red color setting.*
 - Saturation / G(green)*: Adjust a video image from black and white to fully saturated color.
Note: **If the **Color** setting is set to **White**, you can adjust the green color setting.*
 - Gain / B(blue)*: Adjust the image brightness.
Note: **If the **Color** setting is set to **White**, you can adjust the blue color setting.*
 - Reset: Return the factory default settings for color correction.
 - Exit: Exit the “Color Matching” menu.
- **Color Space (HDMI input only)**: Select an appropriate color matrix type from the following: Auto, RGB(0-255), RGB(16-235), and YUV.

Brightness Mode

Adjust the brightness mode settings.

- **DynamicBlack**: Automatically adjusts the brightness based on the source signal for optimum contrast performance.
- **Eco.**: Energy conservation.
- **Power**: Select the power percentage to adjust the overall brightness.

Reset

Return the factory default settings for color settings.

Display 3D menu

Note:

- *This projector is a 3D ready projector with DLP-Link 3D solution.*
- *Please make sure your 3D glasses are use for DLP-Link 3D before enjoy your video.*
- *Supports Frame Sequential (page flip), Side-by-Side (SBS) and Top Bottom 3D video formats.*
- *To enable 3D mode, the input frame rate should be set to 60Hz only, lower or higher frame rate is not supported.*
- *To reach the best performance, resolution 1920x1080 is recommended, please be noted that 4K (3840x2160) resolution is not supported in 3D mode.*
- *3D from a Blu-Ray 3D is detected and displayed automatically.*

3D Mode

Use this option to disable the 3D function or select the appropriate the 3D function.

- **Off:** Select “Off” to turn off 3D mode.
- **On:** Select “On” to turn on 3D mode.

Note: *If 2D and 3D sources are both connected, turn off 3D when selecting the 2D source.*

3D Format

Use this option to select the appropriate 3D format content.

- **Auto:** When a 3D identification signal is detected, the 3D format is selected automatically.
- **SBS:** Display 3D signal in “Side-by-Side” format.
- **Top and Bottom:** Display 3D signal in “Top and Bottom” format.
- **Frame Sequential:** Display 3D signal in “Frame Sequential” format.

3D Sync Invert

Select whether the right or left eye of the glasses synchronizes first.

Display aspect ratio menu

Aspect Ratio

Select the aspect ratio of the displayed image between the following options:

- **Auto:** Automatically selects the appropriate display format.
- **4:3:** This format is for 4:3 input sources.
- **16:9:** This format is for 16:9 input sources, like HDTV and DVD enhanced for Wide screen TV.
- **Full:** Resize image to fit full screen.
- **L. Box:** Zoom in x1.333 but keep its original image aspect ratio.

Note:

- *Detailed information about LBX mode:*
 - *Some Letter-Box Format DVDs are not enhanced for 16x9 TVs. In this situation, the image will not look right when displaying the image in 16:9 mode. In this situation, please try to use the 4:3 mode to view the DVD. If the content is not 4:3, there will be black bars around the image in 16:9 display. For this type of content, you can use LBX mode to fill the image on the 16:9 display.*
 - *When using an external anamorphic lens, the LBX mode allows you to watch 2.35:1 content, including Anamorphic DVD and HDTV film sources. In this case there are no black bars, light source power and vertical resolution are fully utilized.*

WXGA scaling table (screen type 16:10):

16 : 10 screen	480i/p	576i/p	1080i/p	720p	PC
4x3	Scale to 1066x800.				
16x10	Scale to 1280x800.				
LBX	Scale to 1280x960, then get the central 1280x800 image to display.				
Native mode	1:1 mapping centered.		1:1 mapping display 1280x800.	1280x720 centered.	1:1 mapping centered.
Auto	<ul style="list-style-type: none"> - Input source will be fit into 1280x800 display area and be kept its original aspect ratio. - If source is 4:3, auto resize to 1066 x 800. - If source is 16:9 auto resize to 1280 x 720. - If source is 15:9 auto resize to 1280 x 768. - If source is 16:10 auto resize to 1280 x 800. 				

WXGA auto mapping rule (screen type 16:10):

Auto	Input resolution		Auto/Scale	
	H-resolution	V-resolution	1280	800
4:3	640	480	1066	800
	800	600	1066	800
	1024	768	1066	800
	1280	1024	1066	800
	1400	1050	1066	800
	1600	1200	1066	800
Wide Laptop	1280	720	1280	720
	1280	768	1280	768
	1280	800	1280	800
SDTV	720	576	1280	720
	720	480	1280	720
HDTV	1280	720	1280	720
	1920	1080	1280	720

WXGA scaling table (screen type 16:9):

16 : 9 screen	480i/p	576i/p	1080i/p	720p	PC
4x3	Scale to 960x720.				
16x9	Scale to 1280x720.				
LBX	Scale to 1280x960, then get the central 1280x720 image to display.				
Native mode	1:1 mapping centered.		1:1 mapping display 1280x720.	1280x720 centered.	1:1 mapping centered.
Auto	<ul style="list-style-type: none"> - If this format is select, screen type will auto become 16:9 (1280x720). - If source is 4:3, auto resize to 960x720. - If source is 16:9 auto resize to 1280x720. - If source is 15:9 auto resize to 1200x720. - If source is 16:10 auto resize to 1152x720. 				

WXGA auto mapping rule (screen type 16:9):

Auto	Input resolution		Auto/Scale	
	H-resolution	V-resolution	1280	720
4:3	640	480	960	720
	800	600	960	720
	1024	768	960	720
	1280	1024	960	720
	1400	1050	960	720
	1600	1200	960	720
Wide Laptop	1280	720	1280	720
	1280	768	1200	720
	1280	800	1152	720
SDTV	720	576	1280	720
	720	480	1280	720
HDTV	1280	720	1280	720
	1920	1080	1280	720

1080P scaling table:

16 : 9 screen	480i/p	576i/p	1080i/p	720p	PC
4x3	Scale to 1440x1080.				
16x9	Scale to 1920x1080.				
LBX	Scale to 1920x1440, then get the central 1920x1080 image to display.				
Native mode	- 1:1 mapping centered. - No scaling will be made; the resolution is dependent on which input source and is then displayed.				
Auto	- If this format is select, screen type will auto become 16:9 (1920x1080). - If source is 4:3, auto resize to 1440 x1080. - If source is 16:9 auto resize to 1920x1080. - If source is 16:10 auto resize to 1920 x 1200 and cut 1920x1080 area to display.				

1080P auto mapping rule:

Auto	Input resolution		Auto/Scale	
	H-resolution	V-resolution	1920	1080
4:3	640	480	1440	1080
	800	600	1440	1080
	1024	768	1440	1080
	1280	1024	1440	1080
	1400	1050	1440	1080
	1600	1200	1440	1080
Wide Laptop	1280	720	1920	1080
	1280	768	1800	1080
	1280	800	1728	1080
SDTV	720	576	1350	1080
	720	480	1620	1080
HDTV	1280	720	1920	1080
	1920	1080	1920	1080

Display zoom menu

Zoom

Use to reduce or magnify an image on the projection screen.

Note: Pan functions are not supported.

Display keystone menu

Four Corners

This setting allows the projected image to be adjusted from each corner to make a square image when the projection surface is not level.

H Keystone

Adjust image distortion horizontally and make a squarer image. Horizontal keystone is used to correct a keystone image shape in which the left and right borders of the image are unequal in length. This is intended for use with horizontally on-axis applications.

V Keystone

Adjust vertical image distortion making the image more square. Vertical keystone is used to correct a keystone image shape in which the top and bottom borders of the image are unequal in length.

Auto Keystone

Correct keystone digitally to fit the projected image on the area on which you are projecting.

Note: The image size will reduce slightly when adjusting the vertical keystone.

Reset

Return all display settings to factory default settings.

Audio menu

Audio mute menu

Mute

Use this option to temporarily turn off the sound.

- **Off:** Choose “Off” to turn mute off.
- **On:** Choose “On” to turn mute on.

Note:

- “Mute” function affects both internal and external speaker volume.
- When “Mute” is On, you will see the associated icon on top-right side of the screen.

Audio volume menu

Volume

Adjust the speaker or line out volume level.

Setup menu

Setup projection menu

Projection

Select the preferred projection mode from Front or Rear.

Setup projection location menu

Projection Location

Select the preferred projection orientation from Auto, Desktop, or Ceiling.

Setup power settings menu

Auto Power On

Select the automatic power on mode.

- **AC Power On:** The projector is powered on automatically after the power is supplied to the projector.
- **HDMI Power On:** The projector is powered on automatically after the HDMI source is connected to the HDMI 1 or HDMI 2 connector of the projector.

Auto Shutdown (min.)

Sets the countdown timer interval. The countdown timer will start, when there is no signal being sent to the projector. The projector will automatically power off when the countdown has finished (in minutes).

Setup security menu

Security

Enable this function to prompt for a password before using the projector.

- **Off:** Choose “Off” to be able to switch on the projector without password verification.
- **On:** Choose “On” to use security verification when turning on the projector.

Security Timer

Opens the Month/Day/Hour function to set the number of hours the projector can be used. Once the set time is elapsed the password will be required to use the projector.

Change Password

Sets or modifies the security password.



Note:

- *Password default value is “1234” (first time).*
- *When you enter the password, pay enough attention to people around for the password abuse prevention. If you have anxiety the password is cheated, change the password immediately.*

To set the password, do the following:

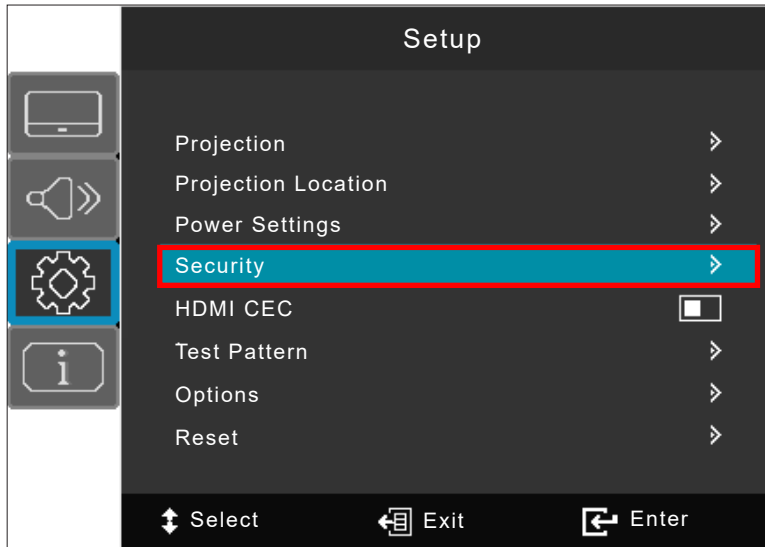
1. Press **Enter**  or  to enter the Security menu.



2. Press **Enter**  or  to select the Change Password item.

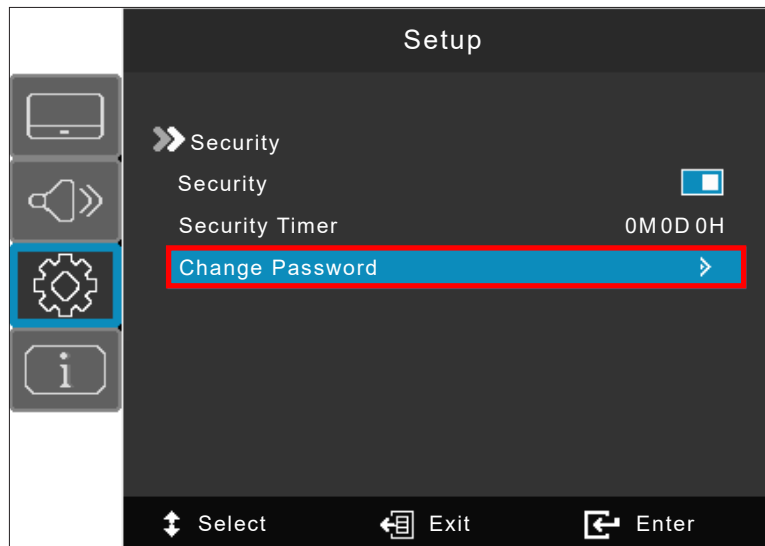

3. Press the number keys on the remote control or the ▲▼ keys on the control panel to select the number. Then press ► to move to the next field and select the number until the 4-digit password is set.

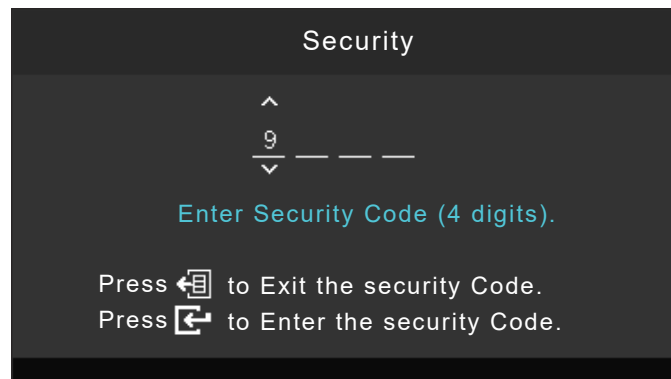
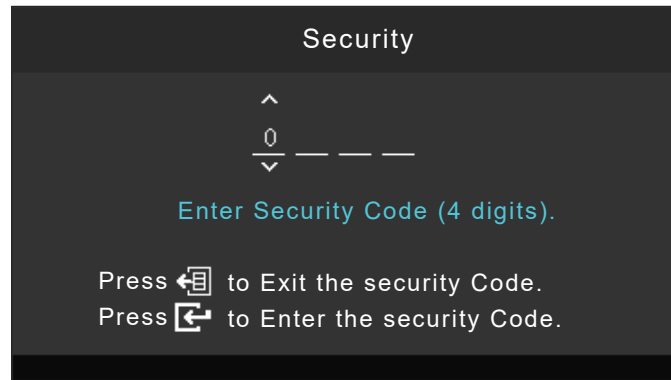

Note: The digits in the password are displayed as [X] symbols for the security reasons.



4. When setting the password is complete, select "Press [Enter] to Enter the security Code." to save the password. The "Security code change successful." will be displayed on the screen.

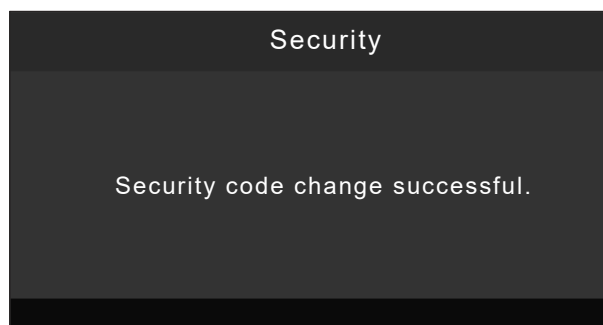

Note: To discard the modifications, select "Press [Exit] to Exit the security Code." to discard the password.

Setup HDMI CEC menu

Note:

- When you connect HDMI CEC-compatible devices to the projector with HDMI cables, you can control them on the same power on or power off status using the HDMI Link control feature in the projector's OSD. This lets one device or multiple devices in a group power on or power off via HDMI Link Feature in a typical configuration, your DVD player may be connected to the projector through an amplifier or home theater system.

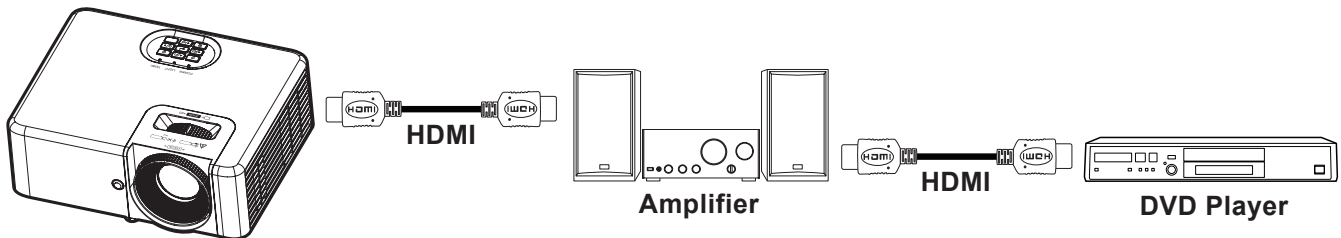

HDMI CEC

Default is Off. Select "On" to enable HDMI CEC function.

Setup test pattern menu

Test Pattern

Select the test pattern from green grid, magenta grid, white grid, white or disable this function (off).

Setup options menu

Language

Select the multilingual OSD menu between English, German, French, Italian, Spanish, Portuguese, Polish, Dutch, Swedish, Norwegian/Danish, Finnish, traditional Chinese, simplified Chinese, Japanese, Korean, Russian, Hungarian, Czechoslovak, Arabic, Thai, Turkish, Vietnamese, and Indonesian.

Auto Source

Choose this option to let the projector automatically find an available input source.

- **Off:** The projector will only search the current input selection. Press the **Source** button on the keypad or on the remote to display a list of sources.
- **On:** The projector automatically finds an available input source. Press the **Source** button on the keypad or on the remote to automatically detect the next source.

High Altitude

When "On" is selected, the fans will spin faster. This feature is useful in high altitude areas where the air is thin.

Reset

Return all settings to factory default settings.

Info menu

Info menu

View the projector information as listed below:

- Serial Number
- Source
- Resolution
- Refresh Rate
- Display Mode
- Light Source Hours

Note: *The value of [Light Source Hours] reflects the [Display Mode] setting in the actual operating time.*

- Brightness Mode
- Firmware Version

ADDITIONAL INFORMATION

Compatible resolutions

6542WL

Input signal for HDMI:

6540HL

Input signal for HDMI2:

Signal	Resolution	Refresh Rate(Hz)
VGA	640 x 480	60/120(*2)
SVGA	800 x 600	60(*2)/72/85/120(*2)
SVGA	832 x 624	75
XGA	1024 x 768	50/60(*2)/70/75/85/120(*2)
XGA	1152 x 870	75
SDTV(480i)	720 x 480	60
SDTV(480p)	720 x 480	60
SDTV(576i)	720 x 576	50
SDTV(576p)	720 x 576	50
WSVGA	1024 x 600	60
HDTV(720p)	1280 x 720	50(*2)/60(*2)
WXGA	1280 x 768	60/75/85
WXGA	1280 x 800	60/120(*2)
WXGA	1280 x 960	60
WXGA	1366 x 768	60
WXGA+	1440 x 900	60
SXGA	1280 x 1024	60/75/85
SXGA+	1400 x 1050	60
UXGA	1600 x 1200	60
HDTV(1080i)	1920 x 1080	50/60
HDTV(1080p)	1920 x 1080	24/30/50/60
WUXGA	1920 x 1200(*1)	60

Note:

- (*1) 1920 x 1200 @60Hz only support RB (reduced blanking).
- (*2) Notes on 3D projection:
 - a) Blu-ray DVD 3D timing input source, projector switch to 3D automatically.
 - b) Frame sequential 120Hz 3D input timing source such as PC, end-user turns on 3D feature from OSD menu.

3D timing

Input resolutions	HDMI 3D Input (with 3D InfoFrame information)	Input timing		
		1280 x 720p @ 50Hz	Top - and - Bottom	
		1280 x 720p @ 60Hz	Top - and - Bottom	
		1280 x 720p @50Hz	Frame packing	
		1280 x 720p @60Hz	Frame packing	
		1920 x 1080i @50Hz	Side- by-Side (Half)	
		1920 x 1080i @60Hz	Side- by-Side (Half)	
		1920 x 1080p @24Hz	Top - and – Bottom	
		1920 x 1080p @24Hz	Frame packing	
	HDMI 3D Input (without 3D InfoFrame information)	1920 x 1080i @50Hz	Side-by-Side(Half)	SBS mode is on
		1920 x1080i @60Hz		
		1280 x 720p @50Hz		
		1280 x 720p @60Hz		
		1920 x 1080i @50Hz		
		1920 x1080i @60Hz	Top-and-Bottom	TAB mode is on
		1280 x 720p @50Hz		
		1280 x 720p @60Hz		
		480i	HQFS (3D format is Frame sequential)	

Note:

- *If 3D input is 1080p@24Hz, the DMD should replay with integral multiple with 3D mode.*
- *1080i@25Hz and 720p@50Hz will run in 100Hz; other 3D timing will run in 120hz.*
- *1080P@24hz will run 144Hz (XGA, WXGA, 1080p)/96Hz (WUXGA).*
- *For Triple Flash 3D mode support - DDP442x is limited to 1920 x 1080 input 3D sources due to ASIC buffer memory limitation. This means WUXGA@24Hz is not supported in triple flash mode (144Hz output rate), it can be processed in double flash mode (96Hz output rate) or the WUXGA input image can be cropped to 1080p before enabling 3D processing.*

6540HL

Input signal for HDMI1:

Signal	Resolution	Refresh Rate(Hz)
VGA	640 x 480	60/120(*2)
SVGA	800 x 600	60(*2)/72/85/120(*2)
SVGA	832 x 624	75
XGA	1024 x 768	50/60(*2)/70/75/85/120(*2)
XGA	1152 x 870	75
SDTV(480i)	720 x 480	60
SDTV(480p)	720 x 480	60
SDTV(576i)	720 x 576	50
SDTV(576p)	720 x 576	50
WSVGA	1024 x 600	60
HDTV(720p)	1280 x 720	50(*2)/60(*2)
WXGA	1280 x 768	60/75/85
WXGA	1280 x 800	60/120(*2)
WXGA	1366 x 768	60
WXGA+	1440 x 900	60
SXGA	1280 x 1024	60/75/85
SXGA+	1400 x 1050	60
UXGA	1600 x 1200	60
HDTV(1080i)	1920 x 1080	50/60
HDTV(1080p)	1920 x 1080	24/30/50/60/120
WUXGA	1920 x 1200(*1)	60
UHD(2160p)	3840 x 2160	24/25/30/50(*3)/60(*3)
4K2K(2160p)	4096 x 2160	24/25(*3)/30(*3)/50(*3)/60(*3)

Note:

- (*1) 1920 x 1200 @60Hz only support RB (reduced blanking).
- (*2) Notes on 3D projection:
 - a) Blu-ray DVD 3D timing input source, projector switch to 3D automatically.
 - b) Frame sequential 120Hz 3D input timing source such as PC, end-user turns on 3D feature from OSD menu.
- (*3) Only 1080p model supports HDMI1 UHD/4K2K timing.

3D timing

Input resolutions	HDMI 3D Input (with 3D InfoFrame information)	Input timing		
			1280 x 720p @ 50Hz	Top - and - Bottom
	1280 x 720p @ 60Hz	Top - and - Bottom		
	1280 x 720p @50Hz	Frame packing		
	1280 x 720p @60Hz	Frame packing		
	1920 x 1080i @50Hz	Side- by-Side (Half)		
	1920 x 1080i @60Hz	Side- by-Side (Half)		
	1920 x 1080p @24Hz	Top - and - Bottom		
	1920 x 1080p @24Hz	Frame packing		
	HDMI 3D Input (without 3D InfoFrame information)	1920 x 1080i @50Hz		
		1920 x 1080i @60Hz	Side-by-Side(Half)	SBS mode is on
		1280 x 720p @50Hz		
		1280 x 720p @60Hz		
		1920 x 1080i @50Hz	Top-and-Bottom	TAB mode is on
		1920 x 1080i @60Hz		
		1280 x 720p @50Hz		
	1280 x 720p @60Hz			
	480i	HQFS (3D format is Frame sequential)		

Note:

- *If 3D input is 1080p@24Hz, the DMD should replay with integral multiple with 3D mode.*
- *1080i@25Hz and 720p@50Hz will run in 100Hz; other 3D timing will run in 120hz.*
- *1080P@24hz will run 144Hz (XGA, WXGA, 1080p)/96Hz (WUXGA).*
- *For Triple Flash 3D mode support - DDP442x is limited to 1920 x 1080 input 3D sources due to ASIC buffer memory limitation. This means WUXGA@24Hz is not supported in triple flash mode (144Hz output rate), it can be processed in double flash mode (96Hz output rate) or the WUXGA input image can be cropped to 1080p before enabling 3D processing.*

Digital compatibility (WXGA: DUKANE 6542WL)

HDMI1				
B0/Established Timing:	B0/Standard Timing:	B0/Detail Timing:	B1/Video Mode	B1/Detail Timing:
720 x 400 @ 70Hz	1280 x 800 @ 60Hz	WXGA: 1280x800 @60Hz	1920 x 1080p @ 60Hz	1366 x 768 @ 60Hz
640 x 480 @ 60Hz	1280 x 1024 @ 60Hz		1920 x 1080p @ 50Hz	1920 x 1080 @ 60Hz
640 x 480 @ 67Hz	1280 x 720 @ 60Hz		640 x 480p @ 60Hz	1280 x 800 @ 120Hz (RB)
640 x 480 @ 72Hz	1600 x 1200 @ 60Hz		720 x 480p @ 60Hz (4:3)	1920 x 1200 @ 60Hz (RB)
640 x 480 @ 75Hz	640 x 480 @ 120Hz		720 x 480p @ 60Hz (16:9)	
800 x 600 @ 56Hz	800 x 600 @ 120Hz		1280 x 720p @ 60Hz	
800 x 600 @ 60Hz	1024 x 768 @ 120Hz		1920 x 1080i @ 60Hz	
800 x 600 @ 72Hz	1280 x 960 @ 60Hz		720(1440) x 480i @ 60Hz	
800 x 600 @ 75Hz			720 x 576p @ 50Hz (4:3)	
832 x 624 @ 75Hz			720 x 576p @ 50Hz (16:9)	
1024 x 768 @ 60Hz			1280 x 720p @ 50Hz	
1024 x 768 @ 70Hz			1920 x 1080i @ 50Hz	
1024 x 768 @ 75Hz			720(1440) x 576i @ 50Hz	
1280 x 1024 @ 75Hz			1920 x 1080p @ 24Hz	
1152 x 870 @ 75Hz				

HDMI2				
B0/Established Timing:	B0/Standard Timing:	B0/Detail Timing:	B1/Video Mode	B1/Detail Timing:
720 x 400 @ 70Hz	1280 x 800 @ 60Hz	WXGA: 1280x800 @60Hz	1920 x 1080p @ 60Hz	1366 x 768 @ 60Hz
640 x 480 @ 60Hz	1280 x 1024 @ 60Hz		1920 x 1080p @ 50Hz	1920 x 1080 @ 60Hz
640 x 480 @ 67Hz	1280 x 720 @ 60Hz		640 x 480p @ 60Hz	1280 x 800 @ 120Hz (RB)
640 x 480 @ 72Hz	1600 x 1200 @ 60Hz		720 x 480p @ 60Hz (4:3)	1920 x 1200 @ 60Hz (RB)
640 x 480 @ 75Hz	640 x 480 @ 120Hz		720 x 480p @ 60Hz (16:9)	
800 x 600 @ 56Hz	800 x 600 @ 120Hz		1280 x 720p @ 60Hz	
800 x 600 @ 60Hz	1024 x 768 @ 120Hz		1920 x 1080i @ 60Hz	
800 x 600 @ 72Hz	1280 x 960 @ 60Hz		720(1440) x 480i @ 60Hz	
800 x 600 @ 75Hz			720 x 576p @ 50Hz (4:3)	
832 x 624 @ 75Hz			720 x 576p @ 50Hz (16:9)	
1024 x 768 @ 60Hz			1280 x 720p @ 50Hz	
1024 x 768 @ 70Hz			1920 x 1080i @ 50Hz	
1024 x 768 @ 75Hz			720(1440) x 576i @ 50Hz	
1280 x 1024 @ 75Hz			1920 x 1080p @ 24Hz	
1152 x 870 @ 75Hz				

Digital compatibility (1080p: DUKANE 6540HL)

HDMI1				
B0/Established Timing:	B0/Standard Timing:	B0/Detail Timing:	B1/Video Mode	B1/Detail Timing:
720 x 400 @ 70Hz	1280 x 800 @ 60Hz	1920 x 1080 @ 60Hz	3840 x 2160p @ 60Hz	1366 x 768 @ 60Hz
640 x 480 @ 60Hz	1280 x 1024 @ 60Hz		3840 x 2160p @ 50Hz	1920 x 1080 @ 120Hz
640 x 480 @ 67Hz	1280 x 720 @ 60Hz		1920 x 1080p @ 60Hz	1920 x 1200 @ 60Hz (RB)
640 x 480 @ 72Hz	1600 x 1200 @ 60Hz		1920 x 1080p @ 50Hz	
640 x 480 @ 75Hz	640 x 480 @ 120Hz		720 x 480p @ 60Hz	
800 x 600 @ 56Hz	800 x 600 @ 120Hz		1280 x 720p @ 60Hz	
800 x 600 @ 60Hz	1024 x 768 @ 120Hz		1920 x 1080i @ 60Hz	
800 x 600 @ 72Hz	1280 x 800 @ 120Hz		1920 x 1080 @ 120Hz	
800 x 600 @ 75Hz			720 x 576p @ 50Hz (16:9)	
832 x 624 @ 75Hz			1280 x 720p @ 50Hz	
1024 x 768 @ 60Hz			1920 x 1080i @ 50Hz	
1024 x 768 @ 70Hz			1920 x 1080p @ 24Hz	
1024 x 768 @ 75Hz			3840 x 2160p @ 24Hz	
1280 x 1024 @ 75Hz			3840 x 2160p @ 25Hz	
1152 x 870 @ 75Hz			3840 x 2160p @ 30Hz	
			4096 x 2160p @ 24Hz	
			4096 x 2160p @ 25Hz	
			4096 x 2160p @ 30Hz	
			4096 x 2160p @ 50Hz	
			4096 x 2160p @ 60Hz	

HDMI2				
B0/Established Timing:	B0/Standard Timing:	B0/Detail Timing:	B1/Video Mode	B1/Detail Timing:
720 x 400 @ 70Hz	1280 x 800 @ 60Hz	1920 x 1080 @ 60Hz	1920 x 1080p @ 60Hz	1366 x 768 @ 60Hz
640 x 480 @ 60Hz	1280 x 1024 @ 60Hz		1920 x 1080p @ 50Hz	1920 x 1080 @ 60Hz
640 x 480 @ 67Hz	1280 x 720 @ 60Hz		640 x 480p @ 60Hz	1920 x 1080 @ 120Hz
640 x 480 @ 72Hz	1600 x 1200 @ 60Hz		720 x 480p @ 60Hz (4:3)	1920 x 1200 @ 60Hz (RB)
640 x 480 @ 75Hz	640 x 480 @ 120Hz		720 x 480p @ 60Hz (16:9)	
800 x 600 @ 56Hz	800 x 600 @ 120Hz		1280 x 720p @ 60Hz	
800 x 600 @ 60Hz	1024 x 768 @ 120Hz		1920 x 1080i @ 60Hz	
800 x 600 @ 72Hz	1280 x 800 @ 120Hz		720(1440) x 480i @ 60Hz	
800 x 600 @ 75Hz			720 x 576p @ 50Hz (4:3)	
832 x 624 @ 75Hz			720 x 576p @ 50Hz (16:9)	
1024 x 768 @ 60Hz			1280 x 720p @ 50Hz	
1024 x 768 @ 70Hz			1920 x 1080i @ 50Hz	
1024 x 768 @ 75Hz			720(1440) x 576i @ 50Hz	
1280 x 1024 @ 75Hz			1920 x 1080p @ 24Hz	
1152 x 870 @ 75Hz				

Image size and projection distance

The diagram below shows an example of when the projector is used on a desktop.
 Horizontal projection position: Equal distance to the left and right from the center of the lens
 Vertical projection position: (see table below)

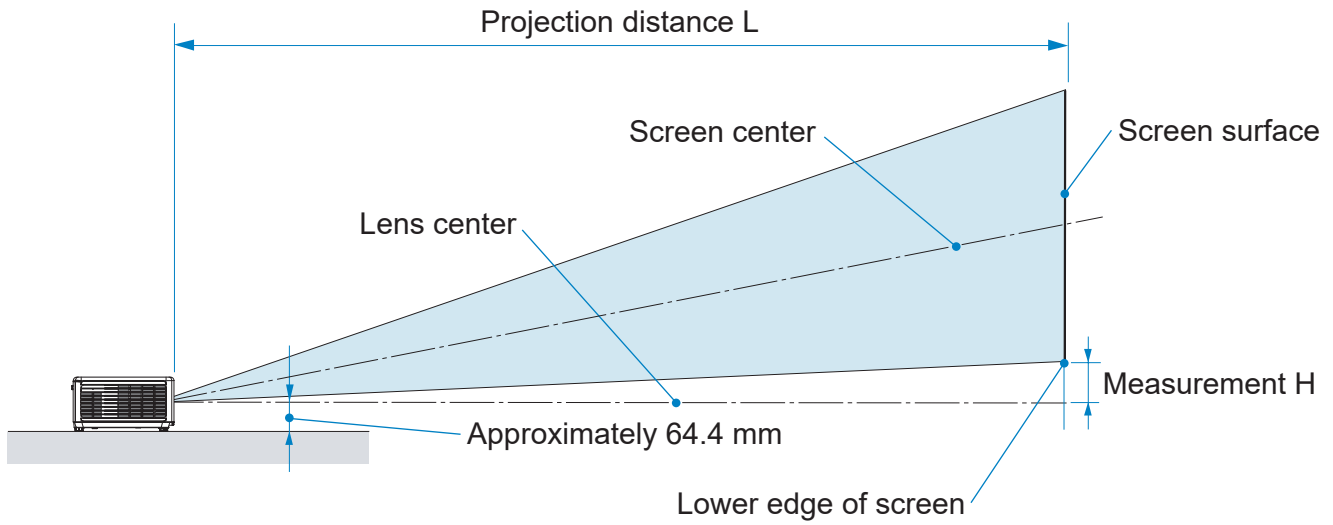

Model: 6540HL

Screen size						Throw distance L				Height H	
Diagonal		Width		Height		Wide		Tele			
(inches)	(cm)	(inches)	(cm)	(inches)	(cm)	(inches)	(m)	(inches)	(m)	(inches)	(cm)
31	79	27	68.6	15	38.6	–	–	38.5	0.98	2.4	6.2
40	102	35	88.6	20	49.8	39.6	1.01	50.0	1.27	3.1	8.0
60	152	52	132.8	29	74.7	59.8	1.52	75.6	1.92	4.7	12.0
80	203	70	177.1	39	99.6	80.1	2.03	101.3	2.57	6.3	15.9
100	254	87	221.4	49	124.5	100.3	2.55	126.9	3.22	7.8	19.9
120	305	105	265.7	59	149.4	120.5	3.06	152.5	3.87	9.4	23.9
150	381	131	332.1	74	186.8	150.8	3.83	191.0	4.85	11.8	29.9
180	457	157	398.5	88	224.1	181.2	4.60	229.4	5.83	14.1	35.9
200	508	174	442.8	98	249.1	201.4	5.12	255.0	6.48	15.7	39.8
240	610	209	531.3	118	298.9	241.8	6.14	306.3	7.78	18.8	47.8
270	686	235	597.7	132	336.2	272.1	6.91	–	–	21.2	53.8
300	762	261	664.1	147	373.6	302.5	7.68	–	–	23.5	59.8
312	793	272	690.7	153	388.5	314.6	7.99	–	–	24.5	62.2

Note: Height from lens center to lower edge of screen (with tilt feet screwed in)

Model: 6542WL

Screen size						Throw distance L				Height H	
Diagonal		Width		Height		Wide		Tele			
(inches)	(cm)	(inches)	(cm)	(inches)	(cm)	(inches)	(m)	(inches)	(m)	(inches)	(cm)
30	76	25	64.6	16	40.4	–	–	38.1	0.97	2.0	5.0
40	102	34	86.2	21	53.8	39.4	1.00	51.1	1.30	2.6	6.7
60	152	51	129.2	32	80.8	59.6	1.51	77.3	1.96	3.9	10.0
80	203	68	172.3	42	107.7	79.7	2.02	103.5	2.63	5.3	13.4
100	254	85	215.4	53	134.6	99.8	2.54	129.7	3.30	6.6	16.7
120	305	102	258.5	64	161.5	120.0	3.05	155.9	3.96	7.9	20.0
150	381	127	323.1	79	201.9	150.2	3.81	195.2	4.96	9.9	25.0
180	457	153	387.7	95	242.3	180.4	4.58	234.5	5.96	11.8	30.0
200	508	170	430.8	106	269.2	200.5	5.09	260.6	6.62	13.1	33.4
240	610	204	516.9	127	323.1	240.7	6.12	313.0	7.95	15.8	40.1
270	686	229	581.6	143	363.5	270.9	6.88	–	–	17.7	45.1
300	762	254	646.2	159	403.9	301.1	7.65	–	–	19.7	50.1
313	795	265	674.2	166	421.4	314.2	7.98	–	–	20.6	52.2

Note: Height from lens center to lower edge of screen (with tilt feet screwed in)

Projector dimensions and ceiling mount installation

To prevent the projector from falling, install it on the ceiling in a way with sufficient strength to withstand the combined weight of the projector and the ceiling mount unit for an extended period of time.

If you wish to use a third party ceiling mount kit, please ensure the screws used to attach a mount to the projector meet the following specifications:

- Screw type: M4*10
- Minimum screw length: 10mm

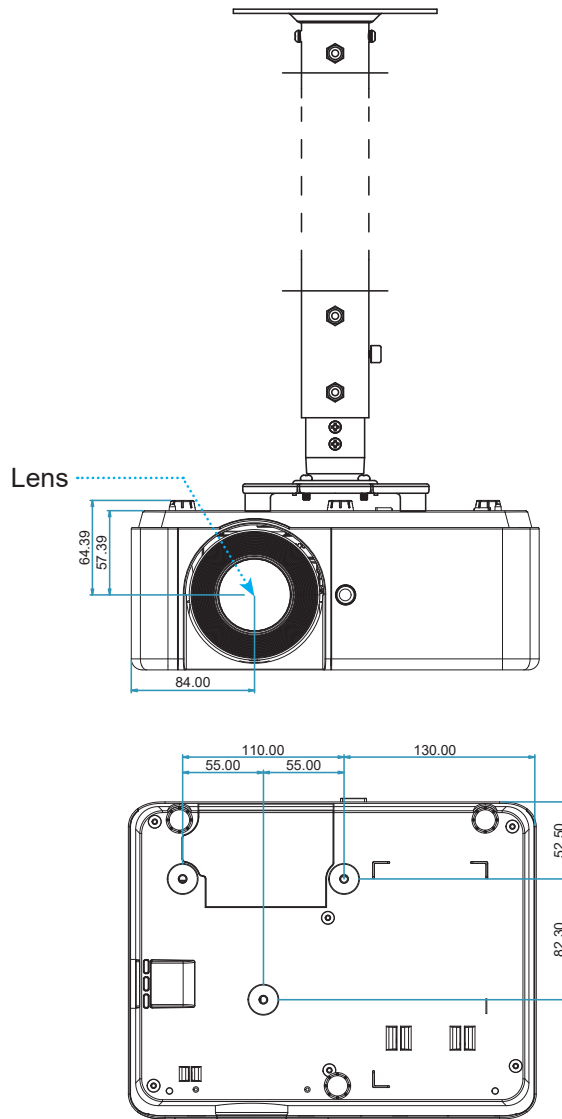

Note: Please note that damage resulting from incorrect installation will void the warranty.



Warning:

- If you buy a ceiling mount from another company, please be sure to use the correct screw size. Screw size will vary depending on the thickness of the mounting plate.
- Be sure to keep at least 10 cm gap between the ceiling and the bottom of the projector.
- Avoid installing the projector near a heat source.

RS232 Commands and Protocol Function List

RS232 Pin Assignments

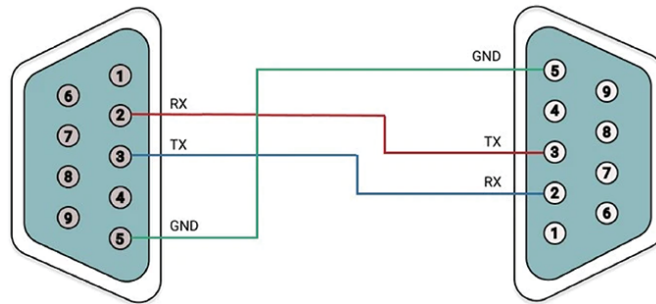

Pin	Signal	Signal Function
1	DCD	Data Carrier Detect
2	RxD	Receive Data
3	TxD	Transmit Data
4	DTR	Data Terminal Ready
5	GND	Ground (Signal)
6	DSR	Data Set Ready
7	RTS	Request to Send
8	CTS	Clear to Send
9	RI	Ring Indicator

Communication Protocol

Communication Protocol	
Baud rate	38400 bps
Data length	8 bits
Parity	No parity
Stop bit	One bit
X on/off	None
Communications procedure	Full duplex

RS232 Command

Function	Code Data									Support (Yes/No)
POWER ON	02H	00H	00H	00H	00H	02H	N/A	N/A		Yes
POWER OFF	02H	01H	00H	00H	00H	03H	N/A	N/A		Yes
INPUT SELECT HDMI1	02H	03H	00H	00H	02H	01H	A1H	A9H		Yes
INPUT SELECT HDMI2	02H	03H	00H	00H	02H	01H	A2H	AAH		Yes
PICTURE MUTE ON	02H	10H	00H	00H	00H	12H	N/A	N/A		Yes
PICTURE MUTE OFF	02H	11H	00H	00H	00H	13H	N/A	N/A		Yes
SOUND MUTE ON	02H	12H	00H	00H	00H	14H	N/A	N/A		Yes
SOUND MUTE OFF	02H	13H	00H	00H	00H	15H	N/A	N/A		Yes
Brightness Mode/Power	03H	B1H	00H	00H	02H	07H	00H	BDH		Yes
Brightness Mode/Eco.	03H	B1H	00H	00H	02H	07H	01H	BEH		Yes

Function	Code Data									<CR>	Support (Yes/No)
POWER ON	50H	4FH	57H	52H	20H	20H	20H	31H	ODH		Yes
POWER OFF	50H	4FH	57H	52H	20H	20H	20H	30H	ODH		Yes
INPUT SELECT HDMI1	49H	52H	47H	42H	20H	20H	33H	31H	ODH		Yes
INPUT SELECT HDMI2	49H	52H	47H	42H	20H	20H	33H	32H	ODH		Yes
PICTURE MUTE ON	49H	4DH	42H	4BH	20H	20H	20H	31H	ODH		Yes
PICTURE MUTE OFF	49H	4DH	42H	4BH	20H	20H	20H	30H	ODH		Yes
SOUND MUTE ON	4DH	55H	54H	45H	20H	20H	20H	31H	ODH		Yes
SOUND MUTE OFF	4DH	55H	54H	45H	20H	20H	20H	30H	ODH		Yes

Response	Code Data			<CR>
OK	4FH	4BH		ODH
ERR	45H	52H	52H	ODH

Troubleshooting

If you experience a problem with your projector, please refer to the following information. If a problem persists, please contact your local reseller or service center.

Image problems

- ❓ *No image appears on screen*
 - Ensure all the cables and power connections are correctly and securely connected as described in the “Installation” section.
 - Ensure the pins of connectors are not crooked or broken.
 - Ensure the “Mute” or “AV Mute” features are not turned on.

- ❓ *Image is out of focus*
 - Turn the focus ring clockwise or counterclockwise until the image is DUKANE and legible. (Please see page 11).
 - Make sure the projection screen is between the required distances from the projector. (Please refer to “Image size and projection distance” section).

- ❓ *The image is stretched when displaying 16:9 DVD title*
 - When playing anamorphic sources or 16:9 sources the projector will display the best image in 16:9 format.
 - When playing a Letterbox (LBX) formatted source change the Aspect Ratio to L. Box.
 - If you play 4:3 format DVD title, please change the format as 4:3 in projector OSD.
 - Please setup the display format as 16:9 (wide) aspect ratio type on your DVD player.

- ❓ *Image is too small or too large*
 - Turn the zoom ring clockwise or counterclockwise to increase or decrease the projected image size. (Please see page 11).
 - Move the projector closer to or further from the screen.
 - Press “Menu” on the projector panel, go to “Display → Aspect Ratio”. Try the different settings.

- ❓ *Image has slanted sides:*
 - If possible, reposition the projector so that it is centered on the screen and below the bottom of the screen.
 - Adjust the vertical or horizontal keystone until the sides are parallel.

- ❓ *Image is reversed*
 - Select “Setup → Projection” from the OSD and adjust the projection mode.

Other problems



The projector stops responding to all controls

- If possible, turn off the projector, then unplug the power cord and wait at least 20 seconds before reconnecting power.

Remote control problems



If the remote control does not work

- Check the operating angle of the remote control is within $\pm 30^\circ$ to the IR receiver on the projector.
- Make sure there are not any obstructions between the remote control and the projector.
Move to within 6 m (19 ft) of the projector.
- Make sure there are no fluorescent light sources shining on the IR receivers.
- Make sure batteries are inserted correctly.
- Replace batteries if they are exhausted.

Warning indicators

When the warning indicators (see below) light up or flash, the projector will automatically shutdown:

- “Light” LED indicator is lit red and if “Power” indicator flashes red.
- “Temp” LED indicator is lit red and if “Power” indicator flashes red. This indicates the projector has overheated. Under normal conditions, the project can be switched back on.
- “Temp” LED indicator flashes red and if “Power” indicator flashes red.

Unplug the power cord from the projector, wait for 30 seconds and try again. If the warning indicators light up or flash please contact your nearest service center for assistance.

LED lightning messages

Message	Power LED		Light LED	Temp LED
	(Red)	(Blue)	(Red)	(Red)
Standby state (input power cord)	Steady light			
Power on (warming)		Flashing (0.5 sec off / 0.5 sec on)		
Power on and light lighting	Steady light			
Power off (cooling)		Flashing (0.5 sec off / 0.5 sec on). Back to red steady light when cooling fan turns off.(*)		
Error (light failure)	Flashing		Steady light	
Error (fan failure)	Flashing			Flashing
Error (over temp.)	Flashing			Steady light
The projector is still available.	Flashing		Flashing	

- Power off:
(*) The projector cannot be operated while it is flashing blue. Please wait. Do not unplug the power cord while it is flashing blue.

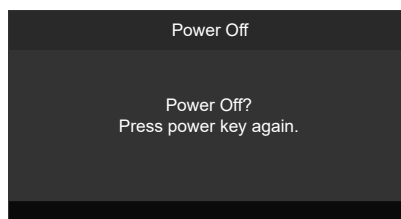

- Temperature warning:

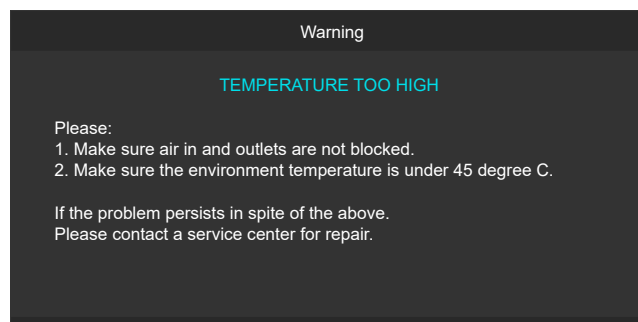

Specifications

This section provides technical information about projector's performance.

Item	Description		
	6540HL	6542WL	
Method	1 Chip DLP type		
Specifications of main parts			
DMD panel	Size	0.65" (aspect ratio: 16:9)	0.65" (aspect ratio: 16:10)
	Pixels (*1)	2,073,600 (1920 dots × 1080 lines)	1,024,000 (1280 dots × 800 lines)
Projection lenses		F=2.45-2.78 / f=17.31~21.61mm	F=2.43-2.78 / f=16.90~21.61mm
	Zoom	<ul style="list-style-type: none"> 6540HL: Manual (Zoom Ratio = 1.267) 6542WL: Manual (Zoom Ratio = 1.3X) 	
	Focus	Manual	
Light source	Laser diode		
Optical device	Optical isolation by dichroic mirror, combining by dichroic prism		
Light output (*2) (*3)	4000 lm	4200 lm	
Screen size (throw distance)	30 to 300 inches (1.0 - 10.8 m)	30 to 300 inches (1.0 - 11.1 m)	
Color reproducibility	10-bit color processing (approx. 1.07 billion colors)		
Scanning frequency			
Horizontal	15 to 140 kHz		
Vertical	24 to 120 Hz		
Input/output terminals			
HDMI	Video input	<ul style="list-style-type: none"> Type A × 2 Deep Color, LipSync, HDCP (*4) 	
	Audio input	<ul style="list-style-type: none"> Sampling frequency: 32/44.1/48 kHz Sampling bit: 16/20/24 bit 	
Audio output	Stereo mini jack × 1		
USB	USB type A × 1, 5.0 V/1.5 A power supply		
Control terminals			
RS232	D-Sub 9-pin × 1, RS232C		
Built-in speaker	8 W (monaural)		
Usage environment			
Operating temperature (*5)	0 to 40°C / 32 to 104°F		
Operating humidity	10 to 80% (with no condensation)		
Storage temperature	-20 to 60°C / -4 to 140°F		
Storage humidity	5 to 90% (with no condensation)		
Operating altitude	0 to 3,048m/10,000 feet (762 to 3,048 m/2,500 to 10,000 feet: Set [HIGH ALTITUDE] to [ON])		
Power specification			
Power supply	19.5 V		
Power consumption	<ul style="list-style-type: none"> 195 W (100-130 V) 190 W (200-240 V) 		
Power consumption (Standby state)	0.5 W		
Rated input current	<ul style="list-style-type: none"> 2.0 A (100-130 V) 1.0 A (200-240 V) 		
Power cord specification	10 A or higher		
Projector dimensions			
External dimensions	<ul style="list-style-type: none"> 10.9" (width) × 4.5" (height) × 8.5" (depth) / 278 (width) × 115.5 (height) × 216 (depth) mm(including protrusions) 10.9" (width) × 4.3" (height) × 8.5" (depth) / 278 (width) × 108.5 (height) × 216 (depth) mm(not including protrusions) 		
Weight	6.6 lbs / 3 kg		
AC adapter specifications			
Model name	EA12321N		
Input	100-240 V AC ± 10% 50/60Hz, 3.5 A		
Output	19.5 V DC, 11.79 A		

Item	Description	
	6540HL	6542WL

Conditions for use at high altitudes

Operating (High-bright mode)

Note:

- All specifications are subject to change without notice.
- (*1) Effective pixels are more than 99.99%.
- (*2) Compliance with ISO 21118-2020.
- (*3) This is the light output value (lumens) when [Display Mode] is set to [High-bright] and [Brightness Mode] is set to [Power 100%]. If any other mode is selected, the light output value may drop slightly.
- (*4) If you are unable to view material via the HDMI input, this does not necessarily mean the projector is not functioning properly. With the implementation of HDCP, there may be cases in which certain content is protected with HDCP and might not be displayed due to the decision/intention of the HDCP community (Digital Content Protection, LLC).
 - Video: Deep Color, 8/10/12-bit, Lip Sync.
 - Audio: LPCM; up to 2 ch, sample rate 32/44.1/48 KHz, sample bit; 16/20/24-bit
 - HDMI: (6540HL) Supports HDCP 2.2 (HDMI1 Connector) HDCP 1.4 (HDMI2 Connector)
(6542WL) Supports HDCP 1.4
- For more information, visit:
 - US: <https://www.DUKANEAV.com>
 - For information on our optional accessories, visit our website or see our brochure.
- (*5) If the temperature inside the projector exceeds the following, the light output value will automatically decrease, and if the temperature rises further, it will automatically shut off the power.

Operating Altitude	Operating temperature when setting [Display Mode]	
	When [Display Mode] is set to [High-bright]	When [Display Mode] is set to other mode
0 ~ 2,500 ft. (0 ~ 762 m)	32~95°F (0~35°C)	32~104°F (0~40°C)
2,500 ~ 5,000 ft. (762 ~ 1,524 m)	32~86°F (0~30°C)	32~95°F (0~35°C)
5,000 ~ 10,000 ft. (1524 ~ 3,048 m)	32~77°F (0~25°C)	32~86°F (0~30°C)

Maintenance

Cleaning the Lens

WARNING

- Turn off the power, unplug the power plug from the socket for cleaning. If the unit turns on while cleaning the lens, the strong light from the lens could damage your eyes. It could also burn your fingers.
- Please do not use a spray containing flammable gas to remove dust attached to the lens. Doing so may result in fires.

You can purchase optic lens cleaner from most camera stores. Refer to the following to clean the projector lens. Remove the lens cap before wiping the lens.

1. Apply a little optic lens cleaner to a clean soft cloth. (Do not apply the cleaner directly to the lens.)
2. Lightly wipe the lens in a circular motion.

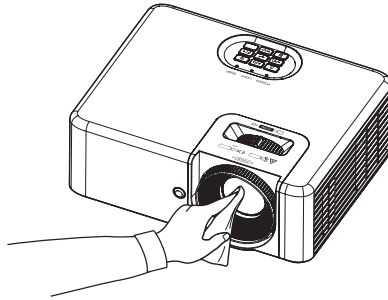

Cleaning the Cabinet

WARNING

- Turn off the projector, and unplug the projector before cleaning.
- Please do not use a spray containing flammable gas to remove dust attached to the cabinet. Doing so may result in fires.

- Use a dry soft cloth to wipe dust off the cabinet. If heavily soiled, use a mild detergent.
- Never use strong detergents or solvents such as alcohol or thinner.
- When cleaning the ventilation slits or the speaker using a vacuum cleaner, do not force the brush of the vacuum cleaner into the slits of the cabinet.

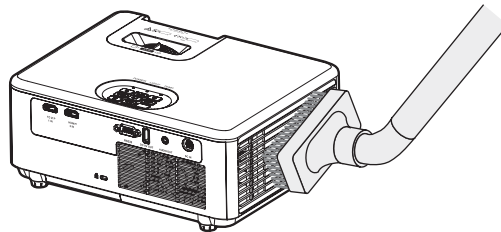

- Clogged ventilation slits may cause a rise in the internal temperature of the projector, resulting in malfunction.
- Do not scratch or hit the cabinet with your fingers or any hard objects
- Contact your dealer for cleaning the inside of the projector.

Note:

- Do not apply volatile agent such as insecticide on the cabinet, the lens, or the screen. Do not leave a rubber or vinyl product in prolonged contact with it. Otherwise the surface finish will be deteriorated or the coating may be stripped off.
-

Cabinet dimensions

Unit: mm (inch)

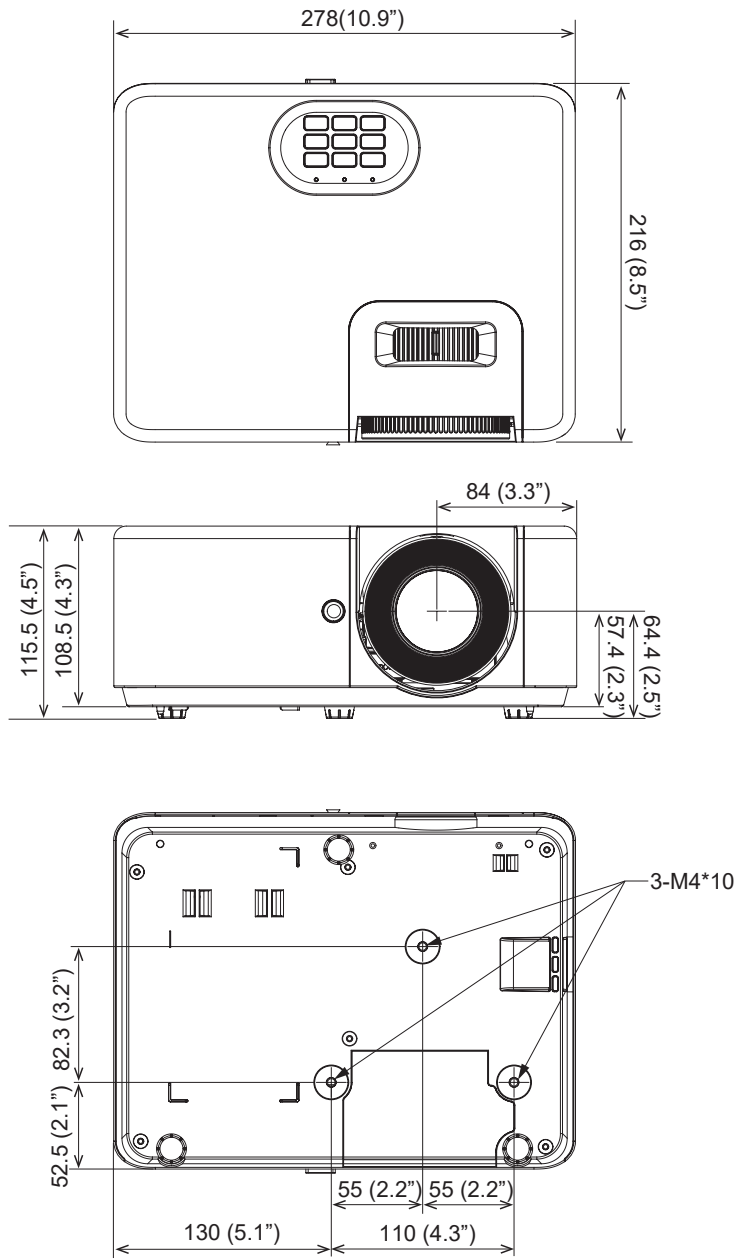

DUKANE